

TECNOINOX

F I T

F I L O

F R A M E

C O L L E C T I O N

2 0 2 3 - 2 0 2 4

ATTREZZATURE INTERNE PER CASSETTI E COLONNE CUCINA

INDEX

5 FIT

6 FIT PORTAPOSATE
FIT CUTLERY INSERT

12 FIT DISPENSA
FIT PULL OUT

25 FILO

26 FILO PORTAPOSATE
FILO CUTLERY INSERT

32 FILO DISPENSA
FILO PULL OUT

45 FRAME

46 FRAME TELAIO CONTENITORE
FRAME CONTAINER FRAME

54 FRAME ACCESSORI CONTENITORI
FRAME INTERIORS ACCESSORIES

89 ACCESSORI

105 CONFIGURAZIONI E FINITURE ACCESSORI

Lo spazio
organizzato verticalmente,
intelligente e creativo.

Space
organized vertically,
smart and creative.

FIT

E' l'innovativo sistema di accessori interni, che si adatta come un abito sartoriale all'interno dei cassetti di ogni cucina, dando massima libertà di configurazione e ordine degli spazi in base al proprio gusto e alle proprie esigenze.

FIT si contraddistingue per la precisa disposizione organizzata in senso verticale e per la sua eleganza adatta ad ogni situazione.

La tipica suddivisione verticale permette di sfruttare al massimo tutti gli spazi.

Ricco e ricercato nel design, FIT è realizzato con una cura e precisione artigianale nei dettagli, utilizzando materiali pregiati di alta qualità.

Tutti gli elementi che compongono la serie sono realizzati a partire da una base in MDF nero in pasta, successivamente impiallacciati con essenze di legno.

Gli elementi divisorii sono in legno massello oppure in alluminio anodizzato o verniciato.

I materiali utilizzati comprendono speciali finiture antigraffio per un uso sempre sicuro e duraturo nel tempo.

Nel sistema FIT sono previste la versione portaposate e la versione dispensa, declinate in differenti composizioni e misure.

FIT is the innovative system of interior accessories that fits like a tailored suit inside the drawers of every kitchen, giving complete freedom to set up and organize spaces, according to every personal demand.

FIT is characterised by the precise vertically organized disposal and by its elegance, adapt to every situation.

The typical vertical disposal allows to make maximum use of all the spaces.

Rich and refined in design, FIT is realized with a craftsman's attention to details, only using the finest high quality materials.

All the elements that make up the series are made from a black MDF base, topped with veneer and wood essences.

The dividing elements can be made of solid wood, anodized aluminum or varnished aluminum.

The materials used include special anti-scratch finishes for a safe and long lasting use.

The FIT system includes the cutlery version and the pullout version, both characterized by different compositions and measures.

FIT PORTAPOSATE FIT CUTLERY INSERT



Gli elementi portaposate FIT si dividono in due tipologie di configurazione.

La prima, con la classica suddivisione degli spazi per la posateria. La seconda, invece, più orientata al contenimento degli accessori e agli attrezzi da cucina. Entrambe possono poi essere arricchite da accessori opzionali come portacoltelli, portapellicole, portaspezie, contenitori in vetro, portacialde caffè, taglieri, etc.

The FIT cutlery elements are divided into two typologies of configuration.

The first, with a classic division of spaces, suitable for cutlery. The second, instead, oriented to the containment of accessories and kitchen tools. Both can then be enriched with optional accessories like knife holders, film holders, spice containers, glass containers, coffee pot holders, cutting boards and so on.





FIT PORTAPOSATE
FIT CUTLERY INSERT

45

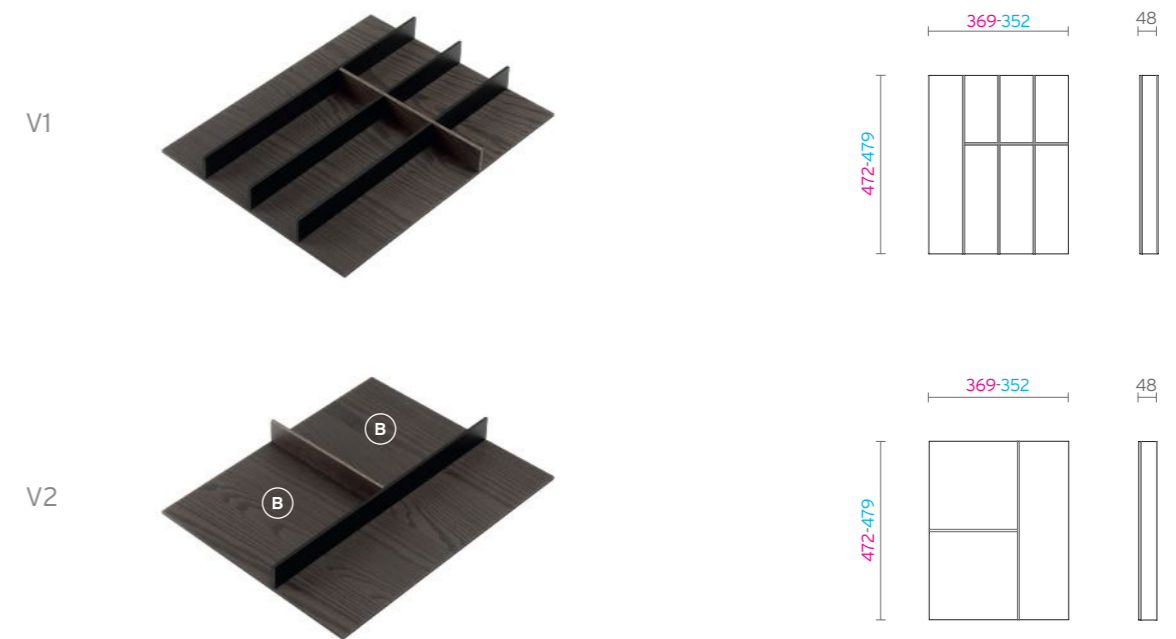

60

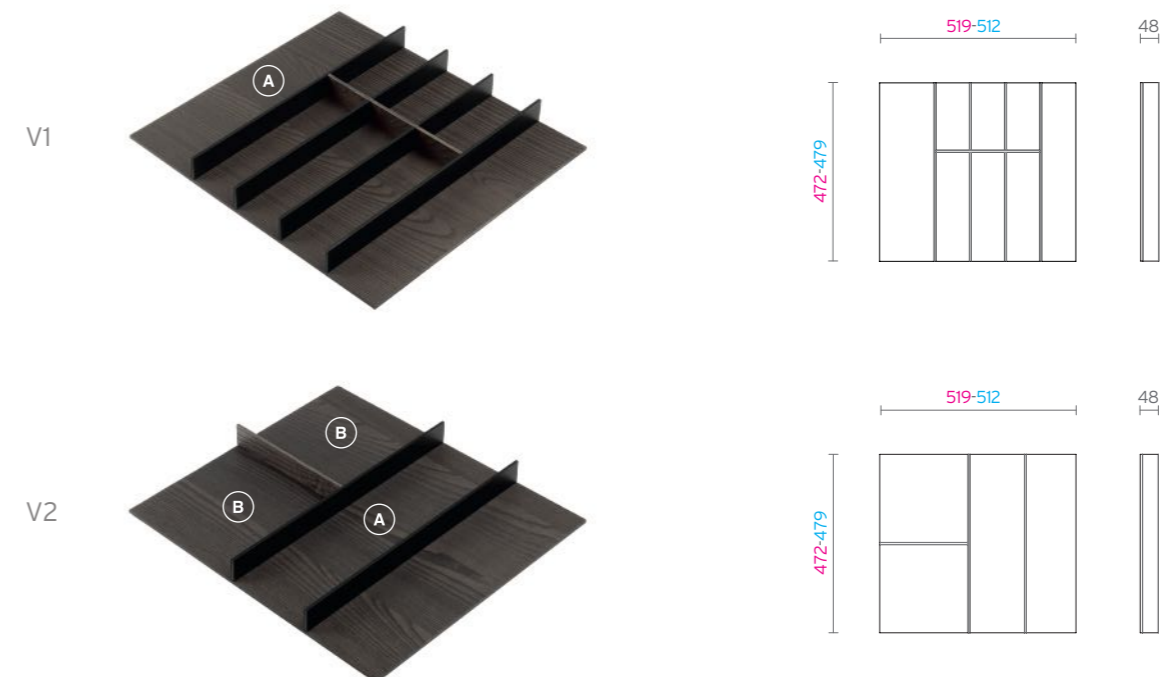

FIT PORTAPOSATE
FIT CUTLERY INSERT

75

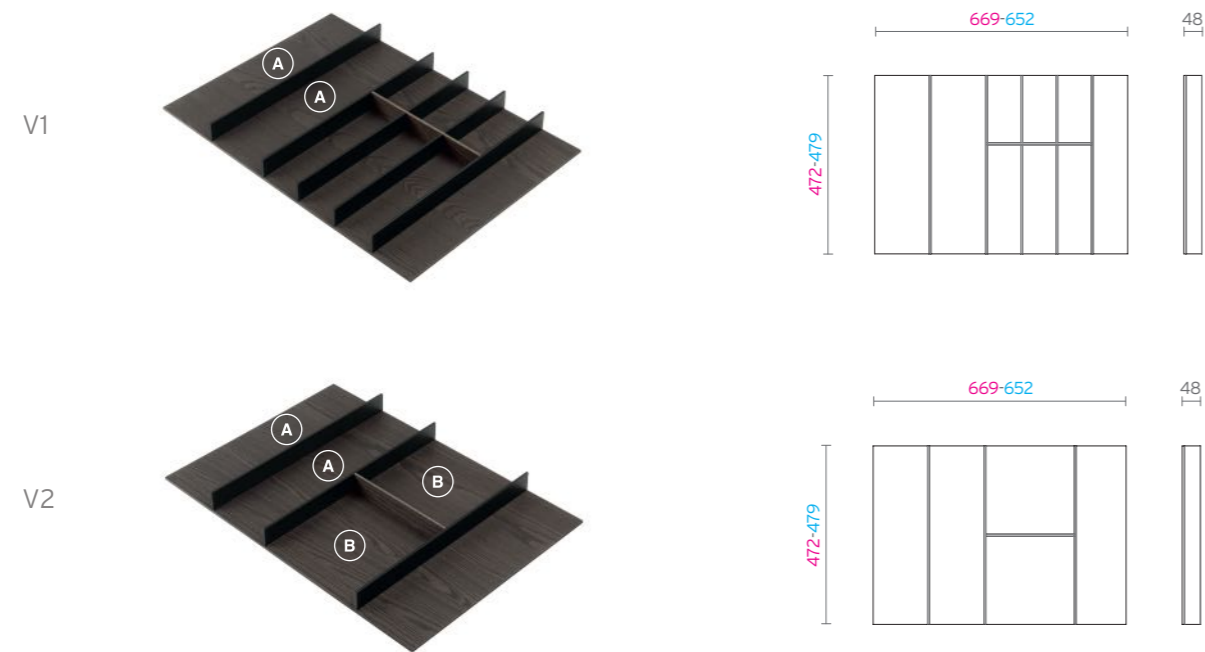

90

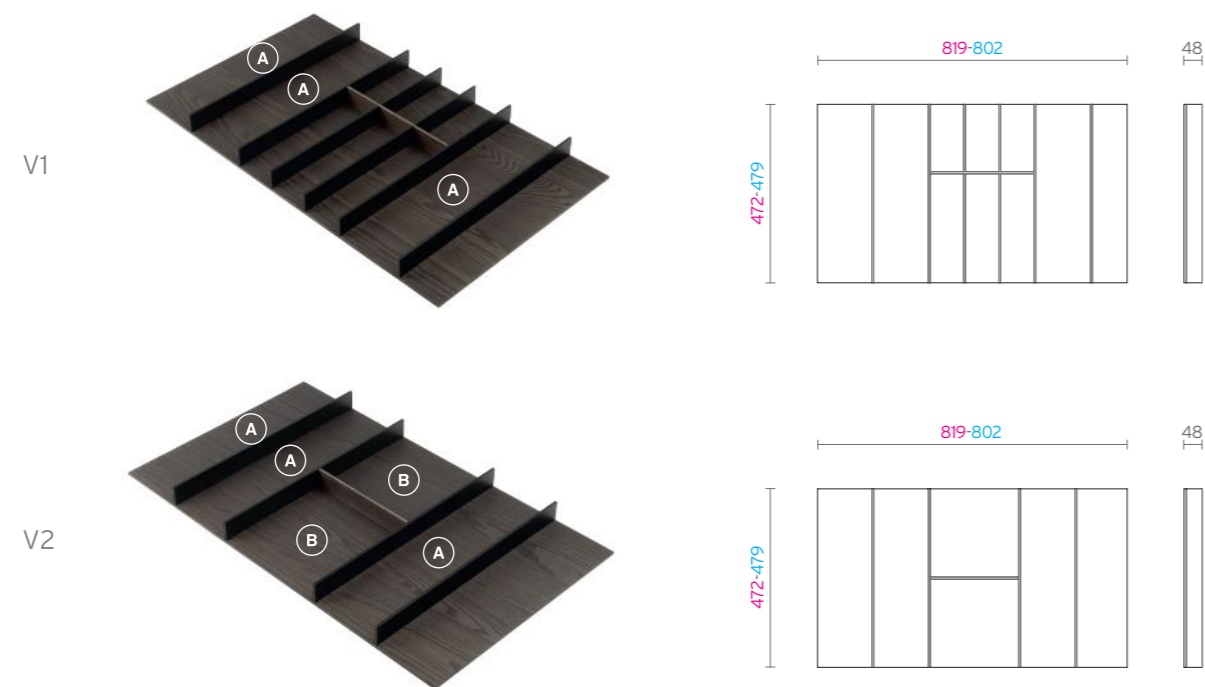

FIT PORTAPOSATE
FIT CUTLERY INSERT

105

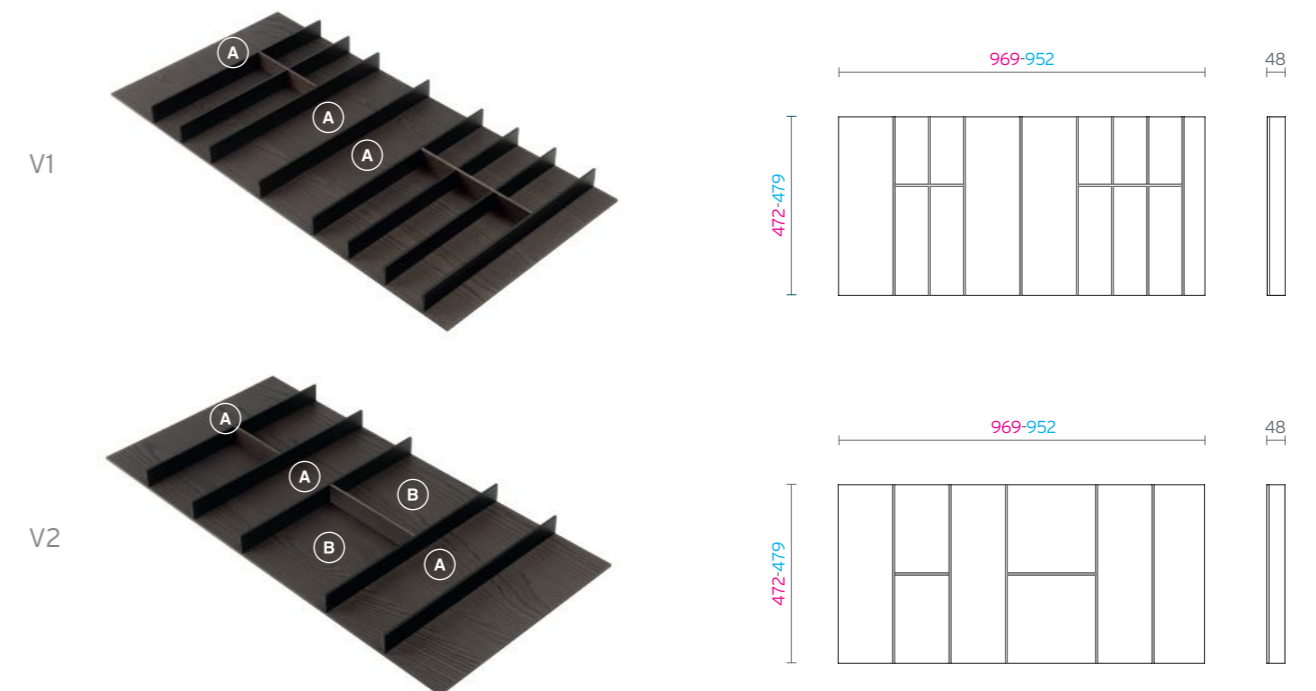

120

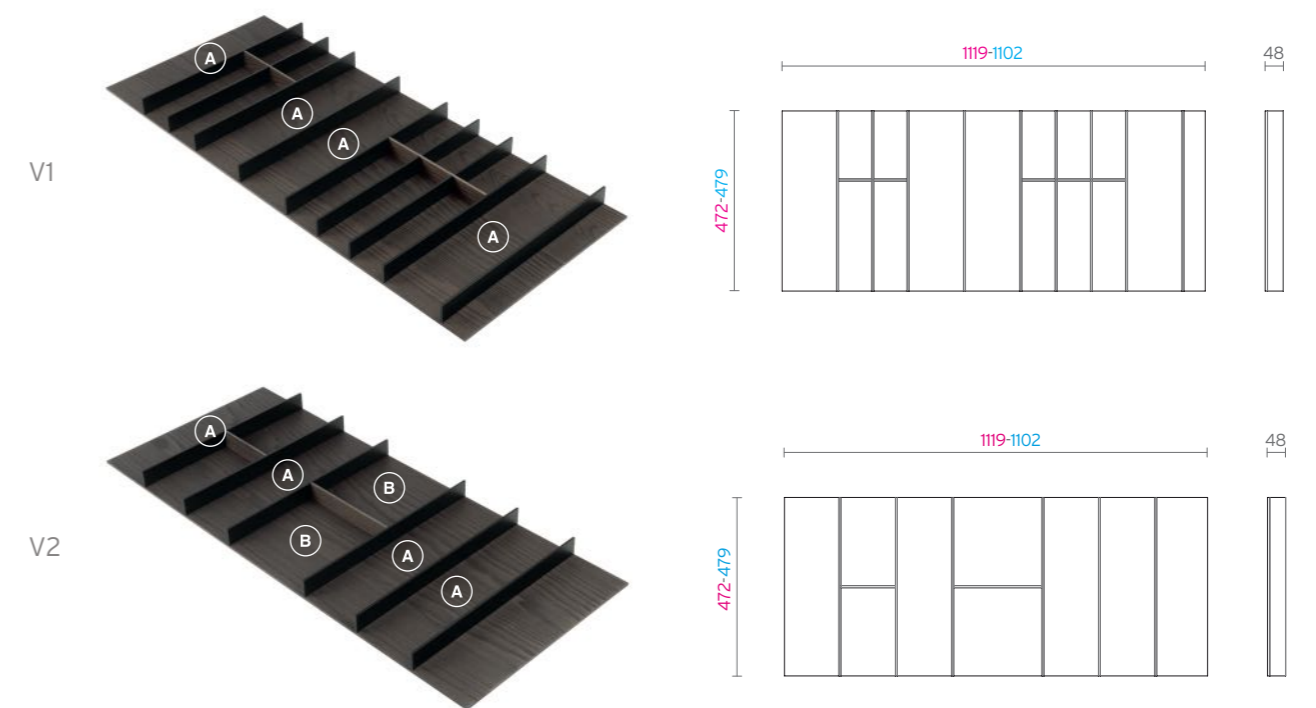

FIT DISPENSA FIT PULL OUT



La dispensa FIT è studiata e configurata in base a funzioni di contenimento specifiche: dispensa portapentole, con eleganti ed efficaci guarnizioni applicate sul fondo per un effetto antiscivolo; dispensa portapiatti, con pilastri di contenimento che possono essere liberamente posizionati per adattarsi ai diversi diametri dei piatti; dispensa con divisori fissi, per riporre scatolame, barattoli, e generi alimentari confezionati.

The FIT pull out has been designed and configured according to specific containment functions: the pot holder, with elegant and functional seals applied to the bottom for a non-slip effect; the dish pullout, with containment pillars that can be freely placed for the adaptation of the different dishes' diameters; the pullout with fixed dividers, to store canned goods, jars and packaged food.



FIT DISPENSA
FIT PULL OUT

60

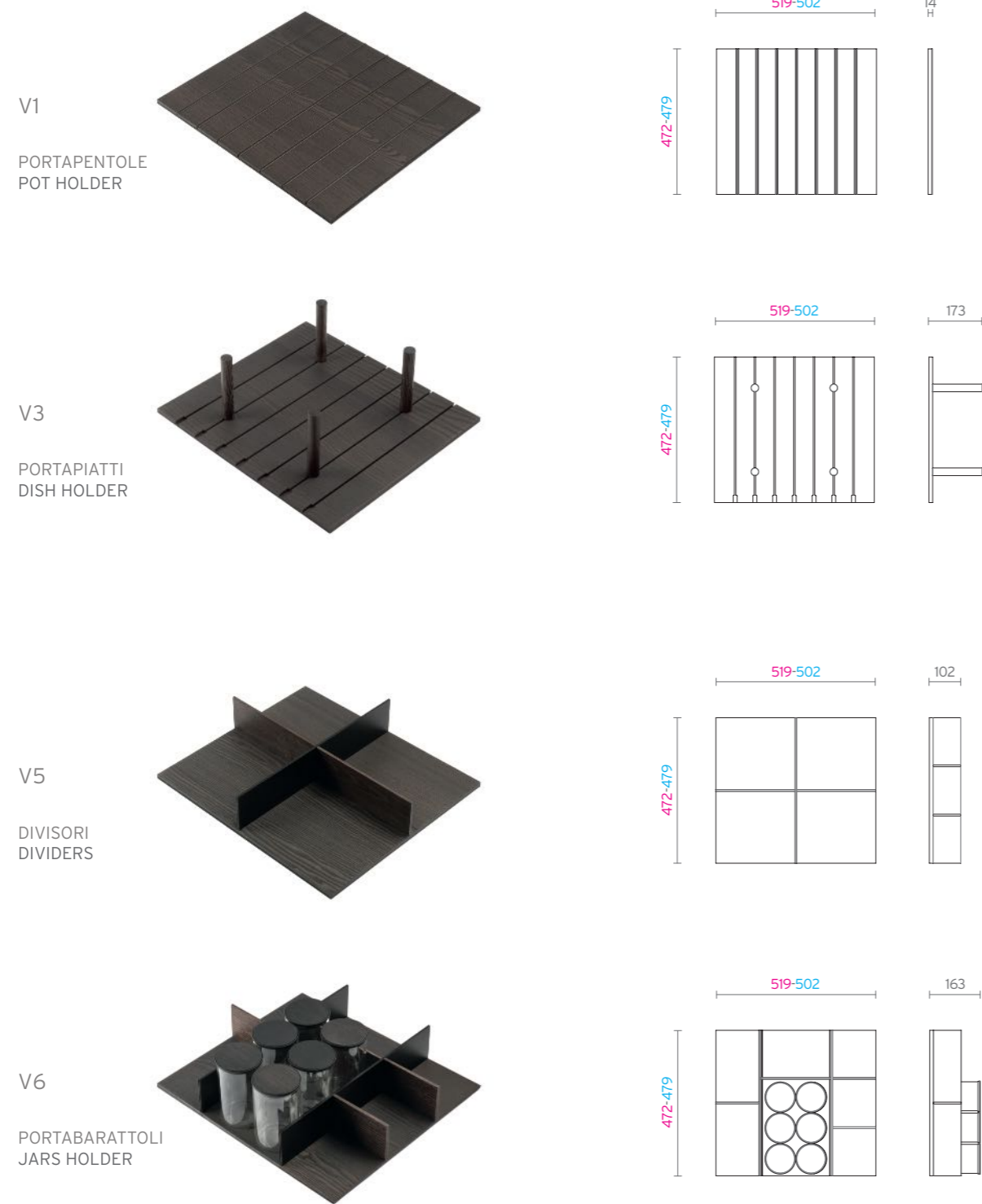

FIT DISPENSA
FIT PULL OUT

60

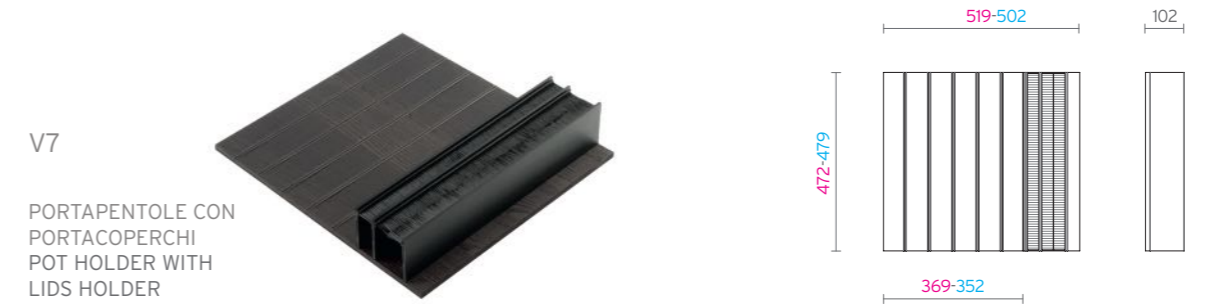

75

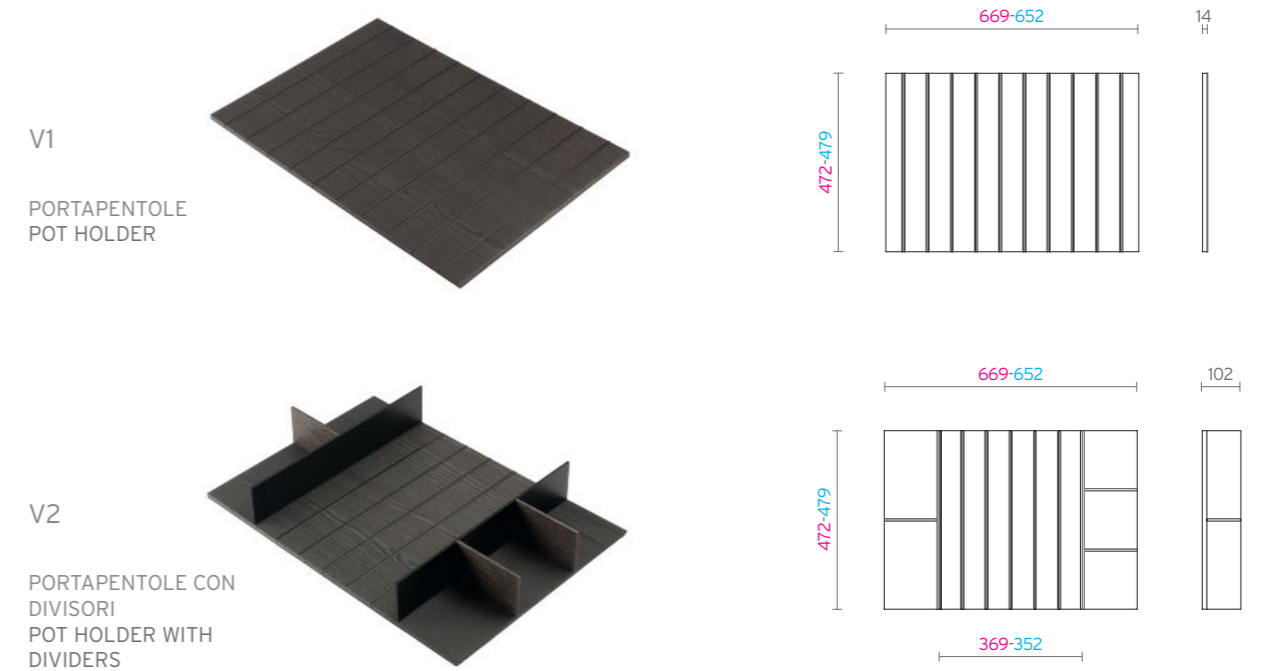

FIT DISPENSA
FIT PULL OUT

75

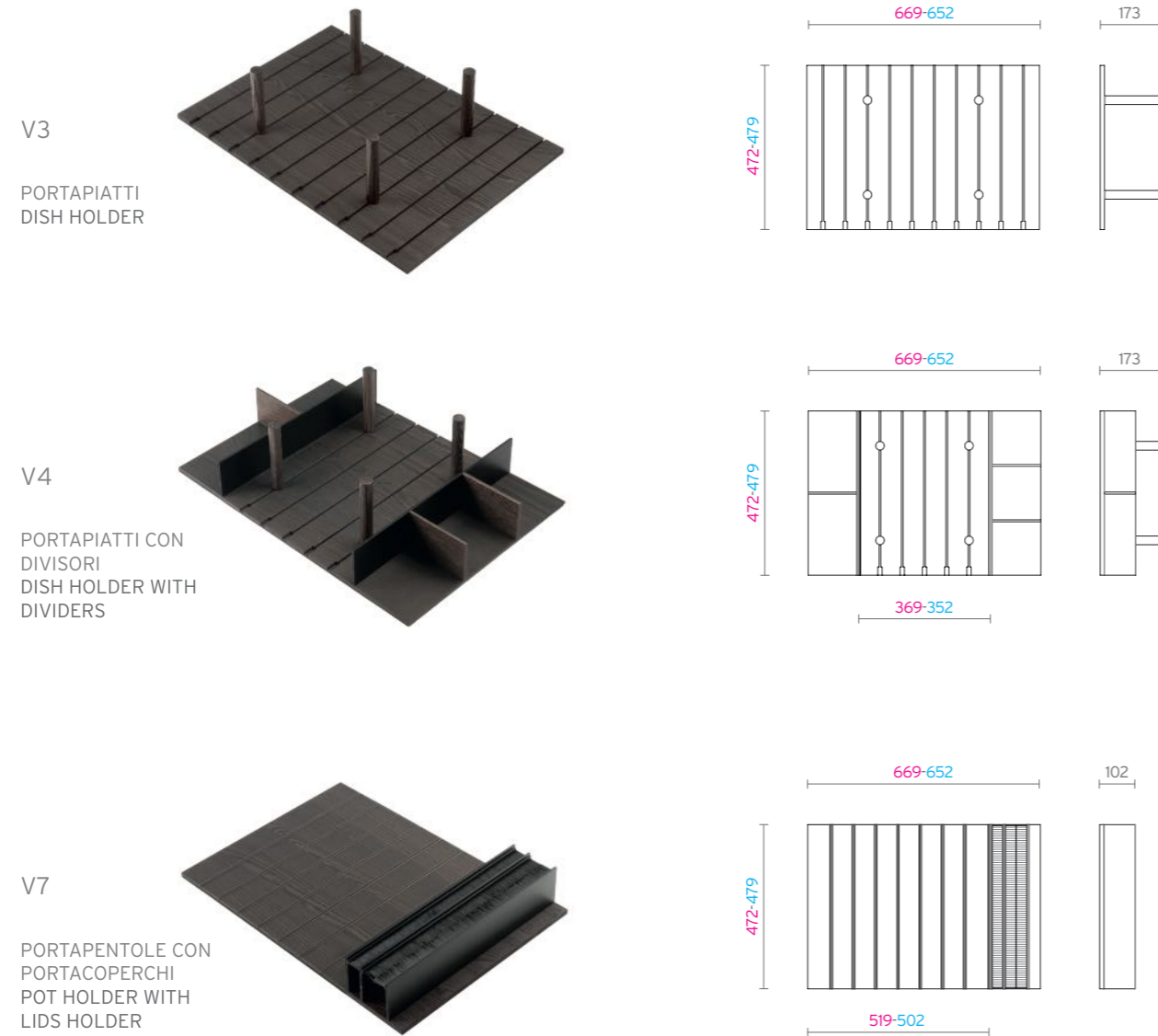

FIT DISPENSA
FIT PULL OUT

90

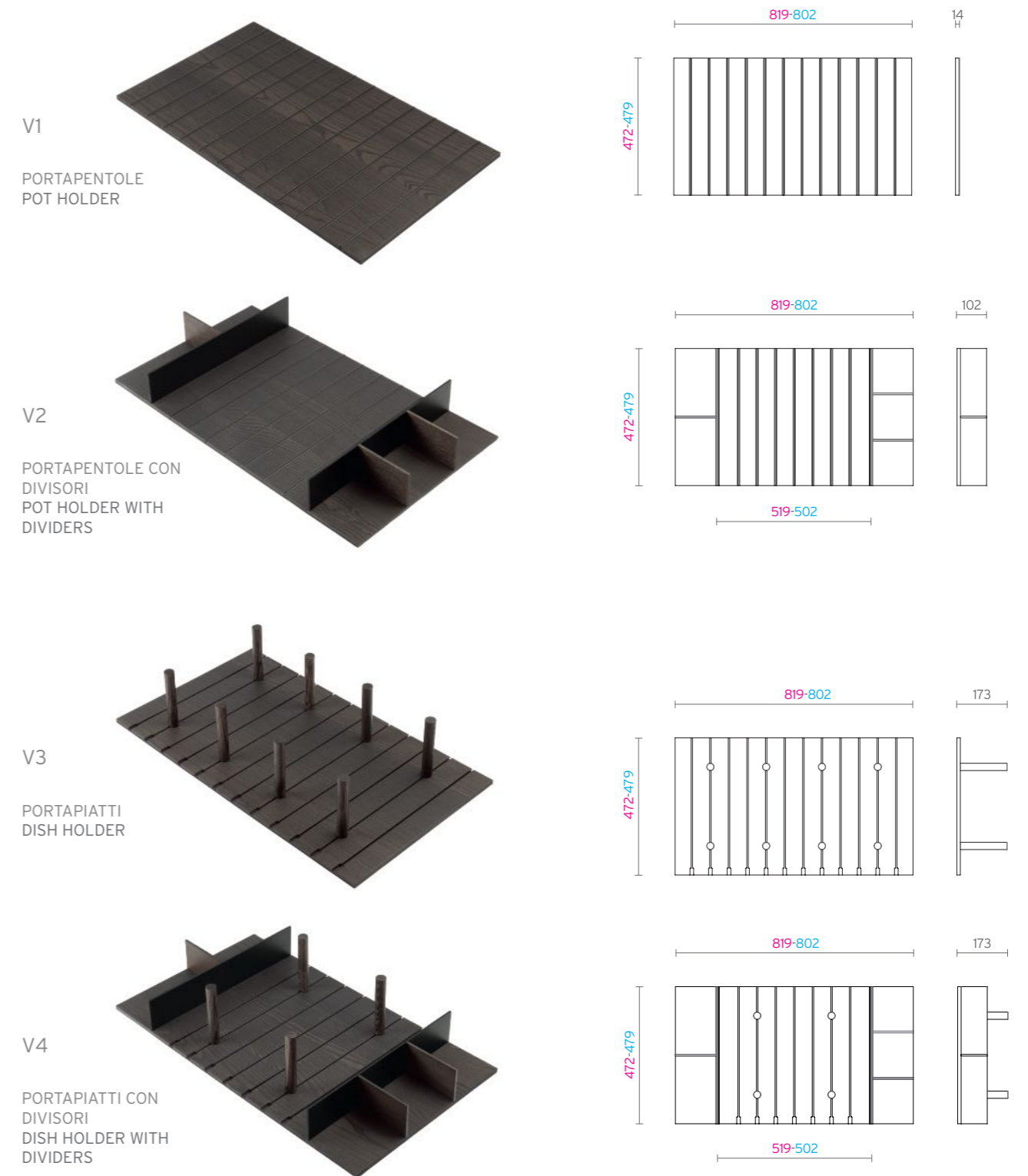

FIT DISPENSA
FIT PULL OUT

90

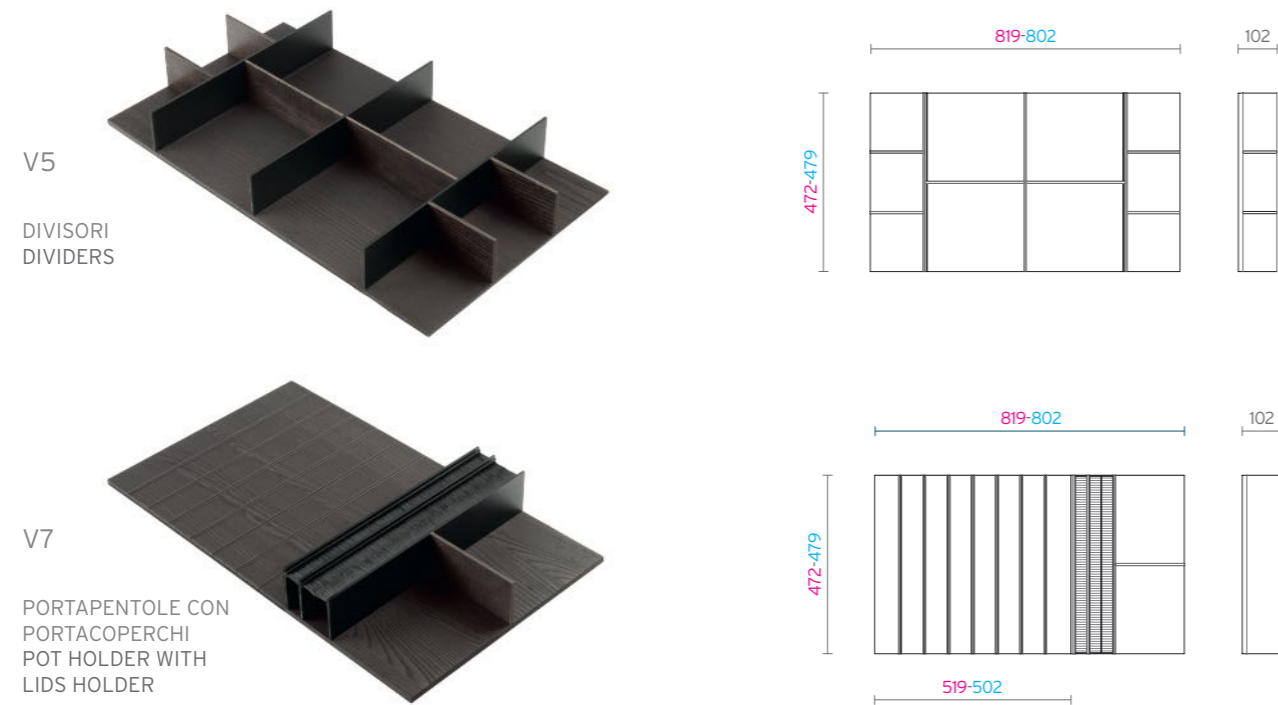

FIT DISPENSA
FIT PULL OUT

105

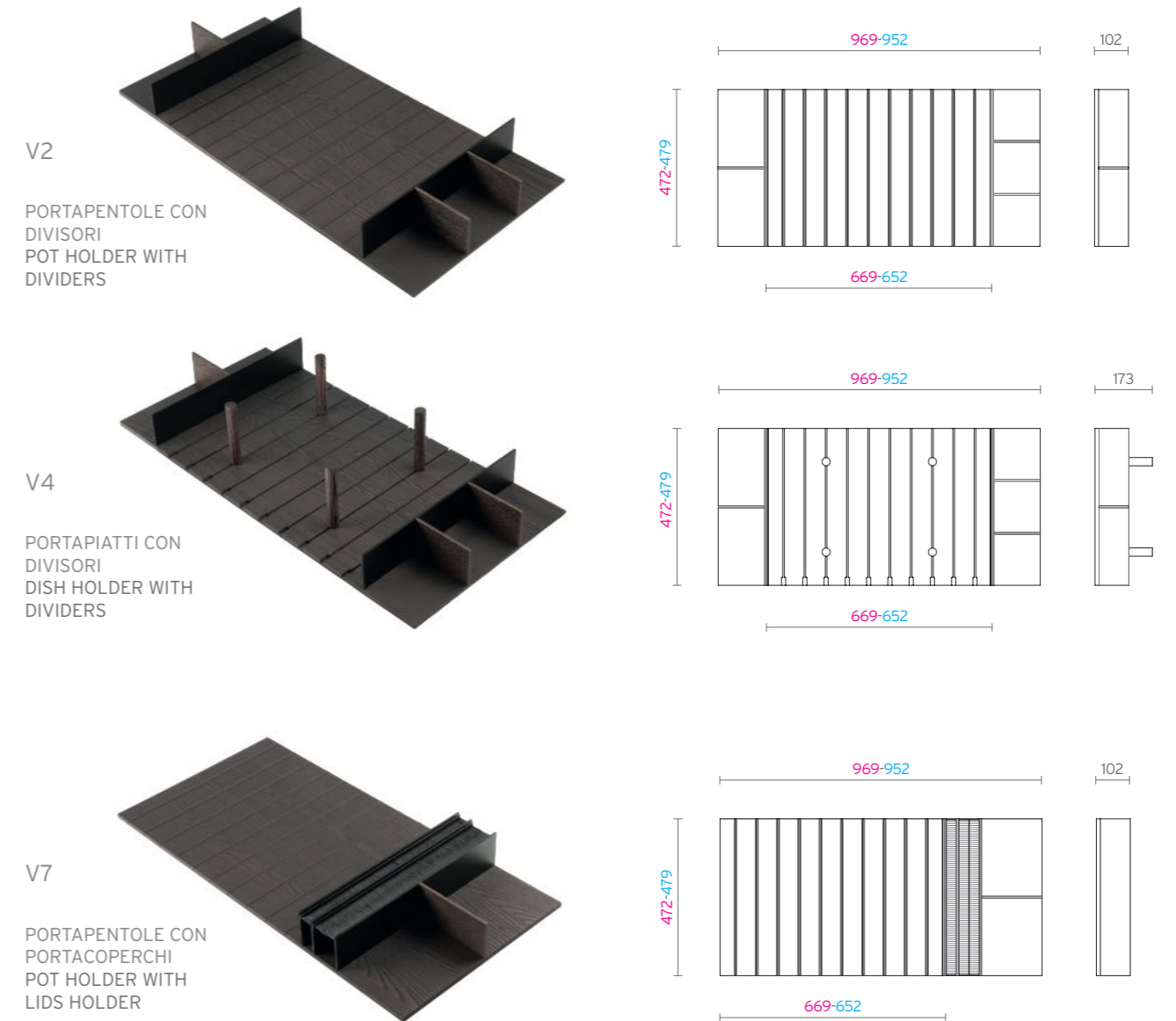

FIT DISPENSA FIT PULL OUT

120

V2	PORTAPENTOLE CON DIVISORI POT HOLDER WITH DIVIDERS		
V4	PORTAPIATTI CON DIVISORI DISH HOLDER WITH DIVIDERS		
V5	DIVISORI DIVIDERS		
V7	PORTAPENTOLE CON PORTACOPERCHI POT HOLDER WITH LIDS HOLDER		





ESEMPI DI CONFIGURAZIONI FIT DISPENSA
CONFIGURATIONS EXAMPLES FOR FIT PULL OUT

ESEMPI DI CONFIGURAZIONI FIT DISPENSA
CONFIGURATIONS EXAMPLES FOR FIT PULL OUT

Lo spazio
organizzato orizzontale,
libero e contemporaneo.

The space
horizontally organized,
free and contemporary.

FILO

E' l'innovativo sistema di accessori interni, che si adatta come un abito sartoriale all'interno dei cassetti di ogni cucina, dando massima libertà di configurazione e ordine degli spazi in base al proprio gusto e alle proprie esigenze.

FILO si contraddistingue per la ripartizione orizzontale degli spazi, seguendo una corrente più contemporanea di utilizzo dell'attrezzatura da cucina. Originale ed elegante permette di utilizzare tutti gli spazi in maniera più creativa.

Ricco e ricercato nel design, FILO è realizzato con una cura e precisione artigianale nei dettagli, utilizzando materiali pregiati di alta qualità.

Tutti gli elementi che compongono la serie sono realizzati a partire da una base in MDF nero in pasta, successivamente impiallacciati con essenze di legno.

Gli elementi divisorii sono in legno massello oppure in alluminio anodizzato o verniciato.

I materiali utilizzati comprendono speciali finiture antigraffio per un uso sempre sicuro e duraturo nel tempo.

Nel sistema FILO sono previste la versione portaposate e la versione dispensa, declinate in differenti composizioni e misure.

FILO is the innovative system of interior accessories that fits like a tailored suit inside the drawers of every kitchen, giving complete freedom to set up and organize spaces, according to every personal demand.

FILO stands out for its spaces disposition, creating an horizontal momentum to align with a more contemporary use of the kitchen's equipment. Original and elegant, it allows to use every space in the most creative way.

Rich and refined in design, FILO is realized with a craftsman's attention to details, only using the finest high quality materials.

All the elements that make up the series are made from a black MDF base, topped with veneer and wood essences.

The dividing elements can be made of solid wood, anodized aluminum or varnished aluminum.

The materials used include special anti-scratch finishes for a safe and long lasting use.

The FILO system includes the cutlery version and the pullout version, both characterized by different compositions and measures.

FILO PORTAPOSATE FILO CUTLERY INSERT

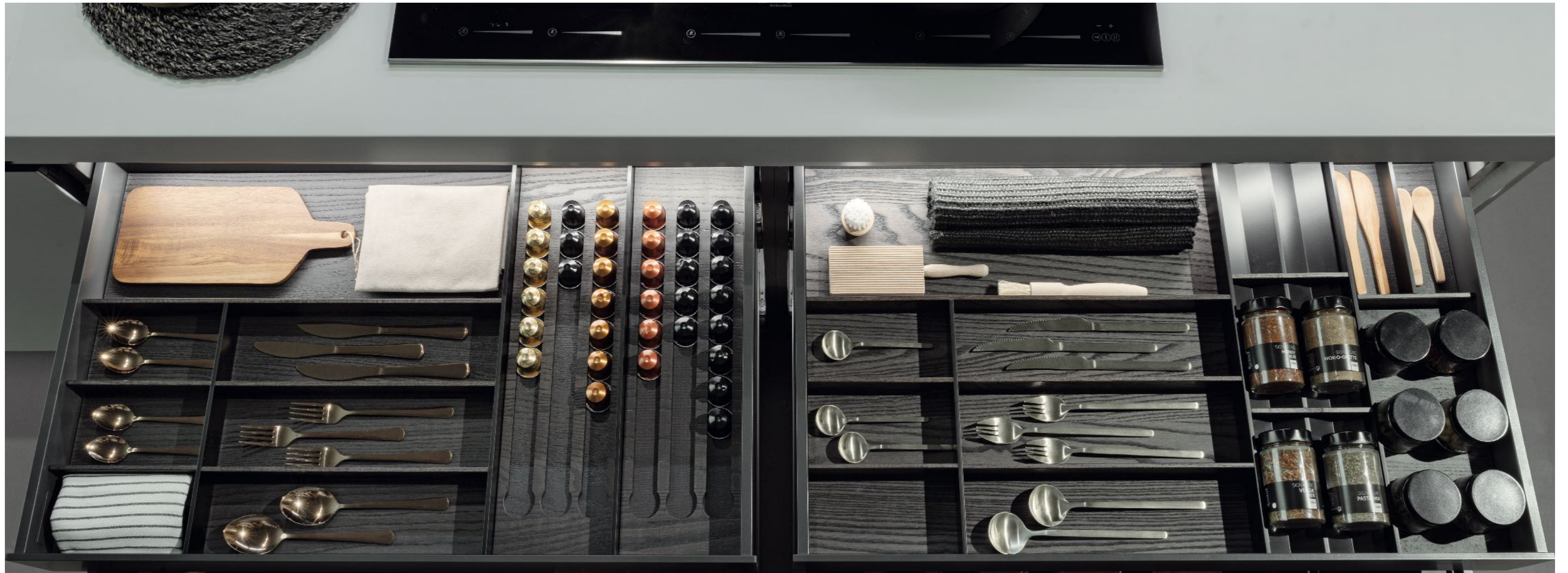

Gli elementi portaposate FILO si dividono in due tipologie di configurazione.

La prima, con la classica suddivisione degli spazi per la posateria. La seconda, invece, più orientata al contenimento degli accessori e agli attrezzi da cucina. Entrambe possono poi essere arricchite da accessori opzionali come portacoltelli, portapellucole, portaspezie, contenitori in vetro, portacialde caffè, taglieri, etc.

The FILO cutlery elements are divided into two typologies of configuration.

The first with the classic division of the spaces for the cutlery, the second, instead, more oriented to contain accessories and kitchen tools. Both can then be enriched with optional accessories like knife holders, film holders, spice containers, glass containers, coffee pot holders, cutting boards and so on.

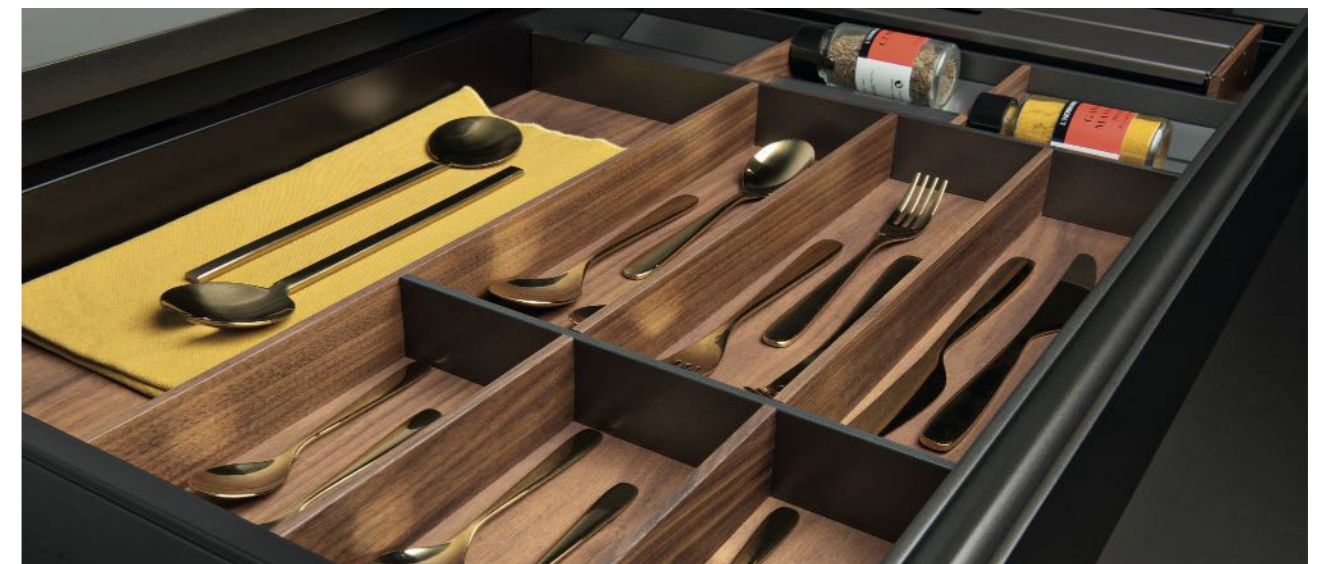



FILO PORTAPOSATE FILO CUTLERY INSERT

45

V1

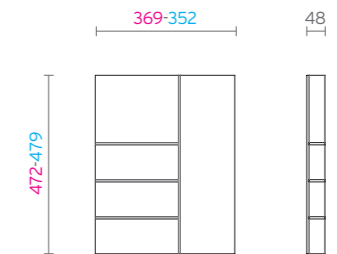

V2

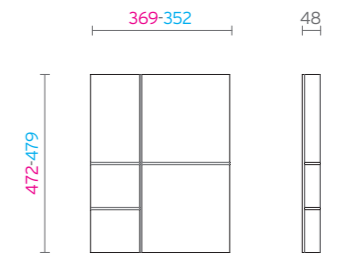
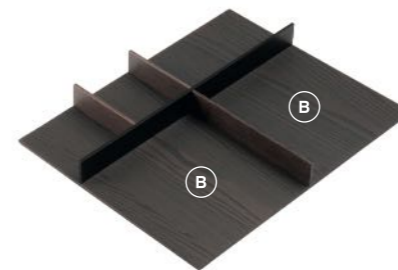

60

V1

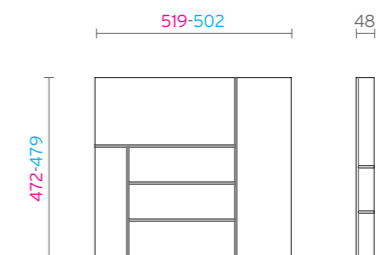

V2

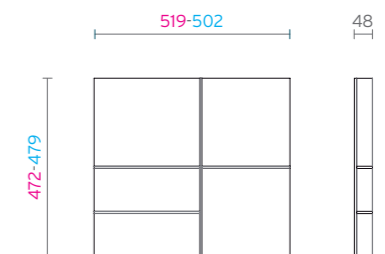

FILO PORTAPOSATE
FILO CUTLERY INSERT

75

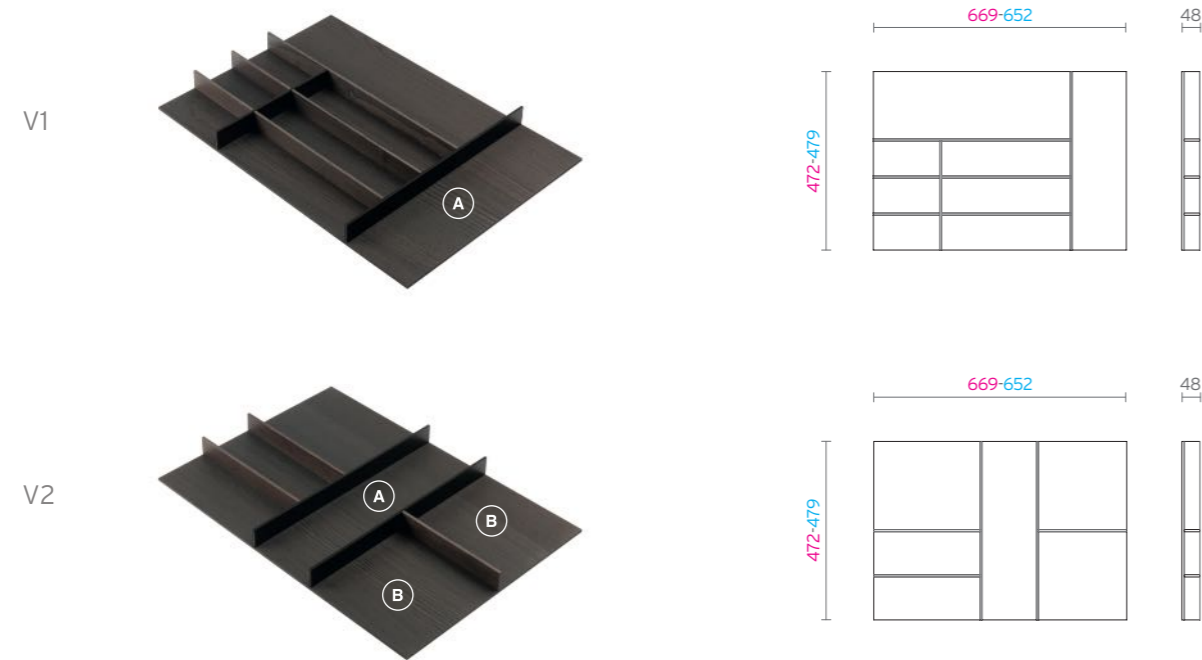

90

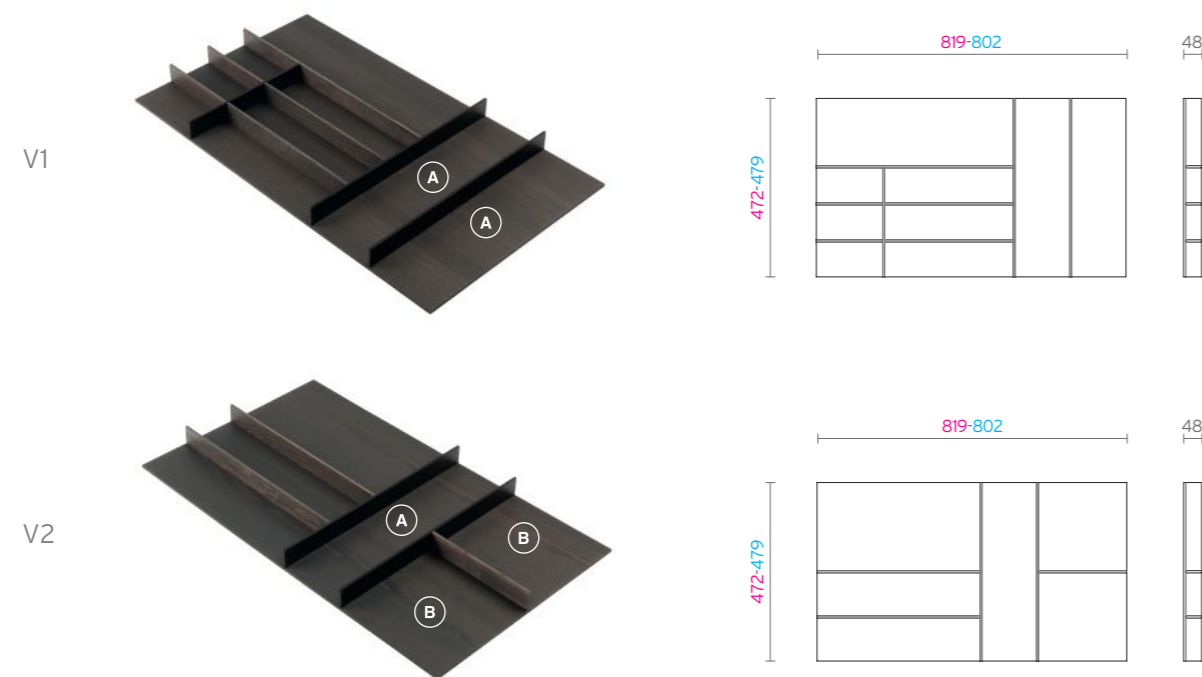

FILO PORTAPOSATE
FILO CUTLERY INSERT

105

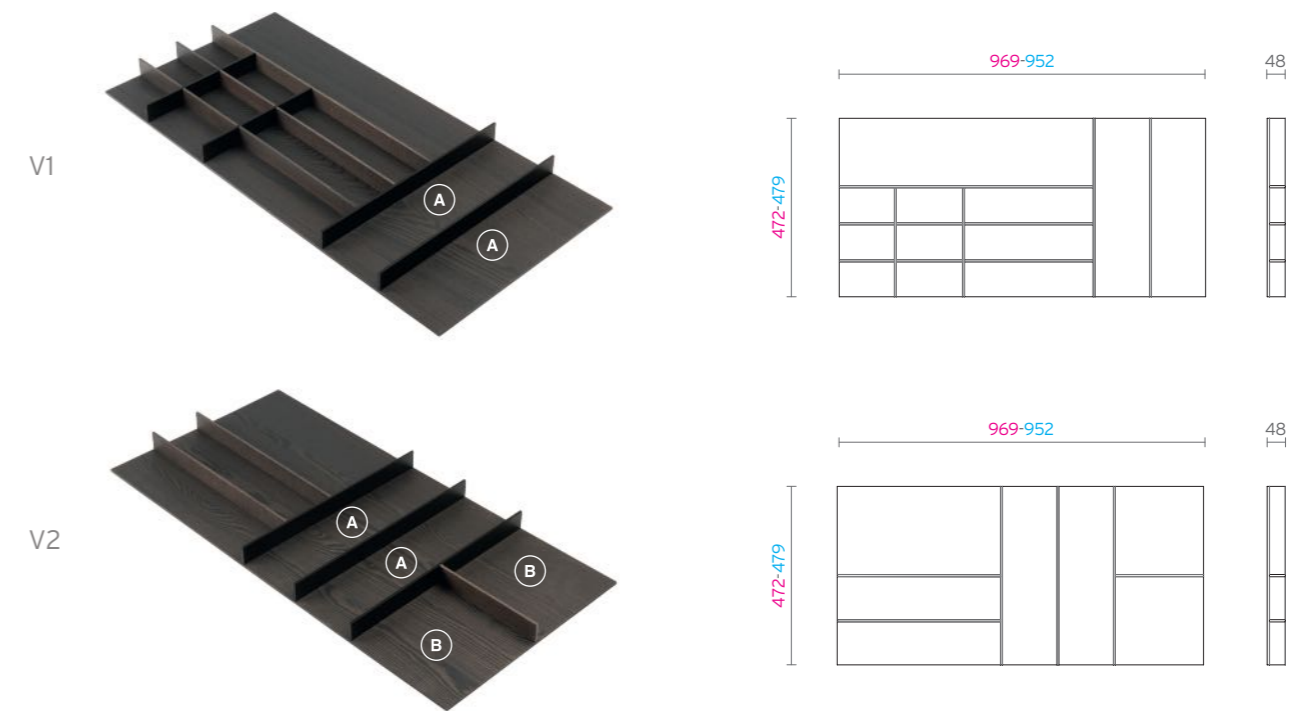

120

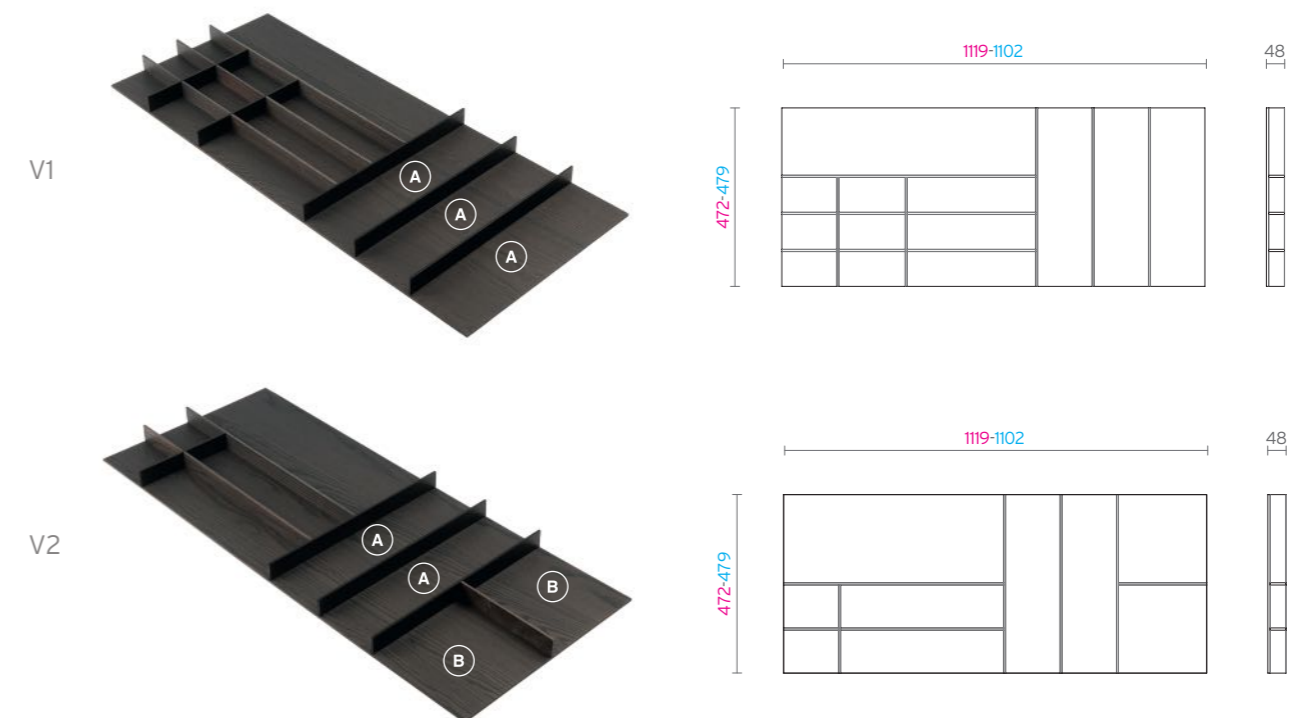

FILO DISPENSA FILO PULL OUT



La dispensa FILO è studiata e configurata in base a funzioni di contenimento specifiche: dispensa portapentole con eleganti ed efficaci guarnizioni applicate sul fondo per un effetto antiscivolo; dispensa portapiatti con pilastri di contenimento che possono essere liberamente posizionati per adattarsi ai diversi diametri dei piatti; dispensa con divisori fissi per riporre scatolame, barattoli, e generi alimentari confezionati.

The FILO pull out has been designed and configured according to specific containment functions: the pot holder with elegant and functional seals applied to the bottom for a non-slip effect; the dish holder pullout with containment pillars, that can be freely placed for the adaptation of the different dishes' diameters, and the pullout with fixed dividers to store canned goods, jars and packaged food.

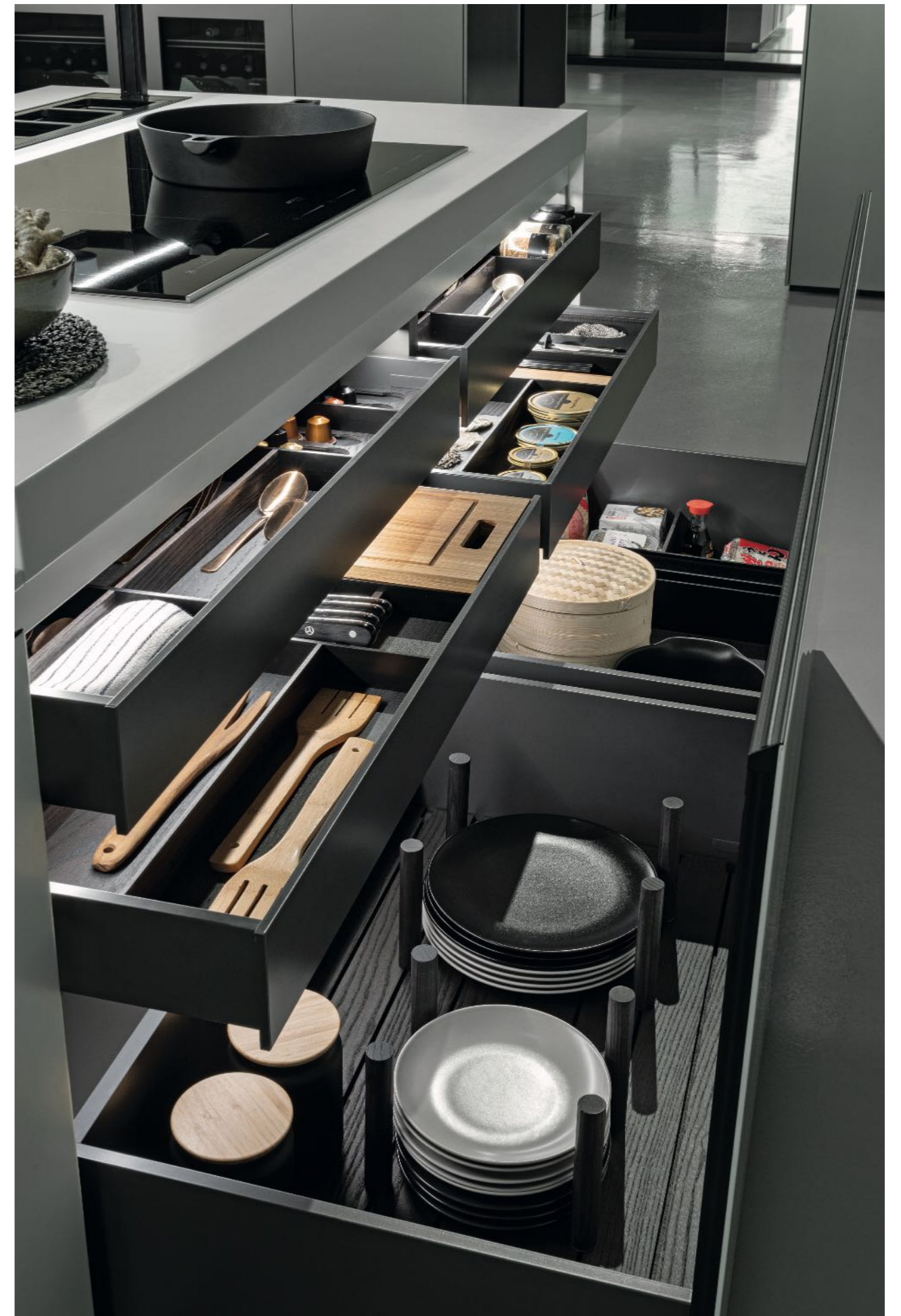

FILO DISPENSA FILO PULL OUT

60



FILO DISPENSA FILO PULL OUT

60

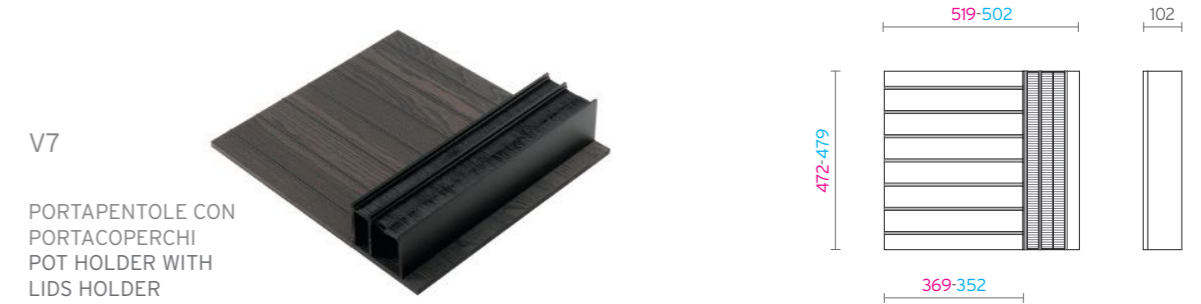

75

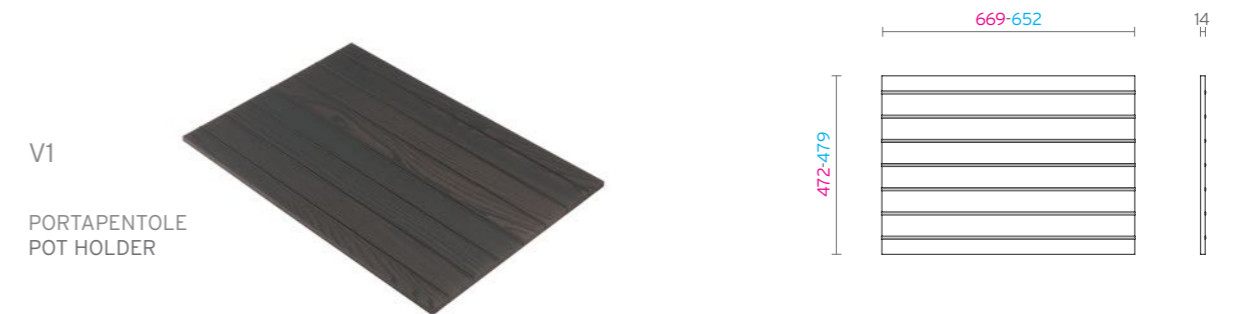

FILO DISPENSA FILO PULL OUT

75

V5
DIVISORI
DIVIDERS

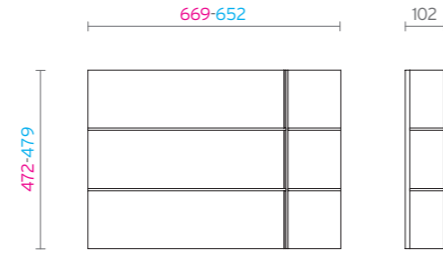
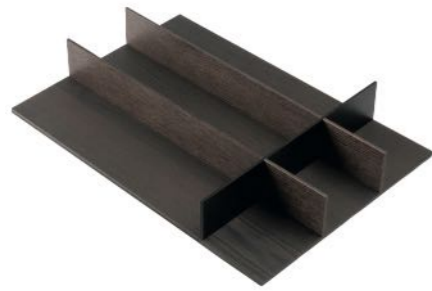

V7
PORTAPENTOLE CON
PORTACOPERCHI
POT HOLDER WITH
LIDS HOLDER

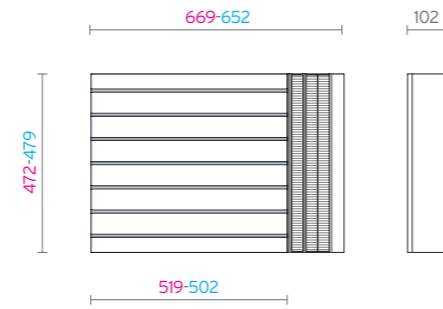

FILO DISPENSA FILO PULL OUT

90

V1
PORTAPENTOLE
POT HOLDER

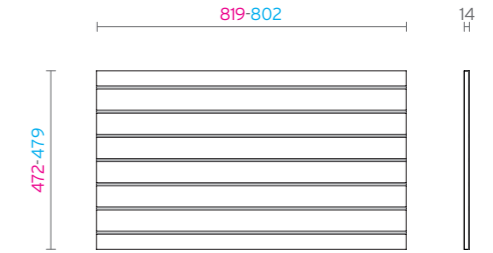

V2
PORTAPENTOLE
CON DIVISORI
POT HOLDER WITH
DIVIDERS

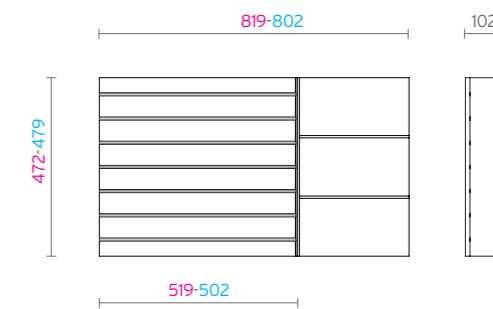

V3
PORTAPIATTI
DISH HOLDER

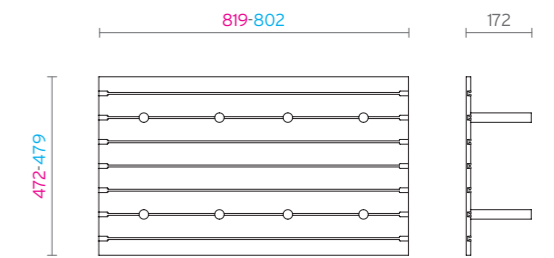

V4
PORTAPIATTI CON
DIVISORI
DISH HOLDER WITH
DIVIDERS

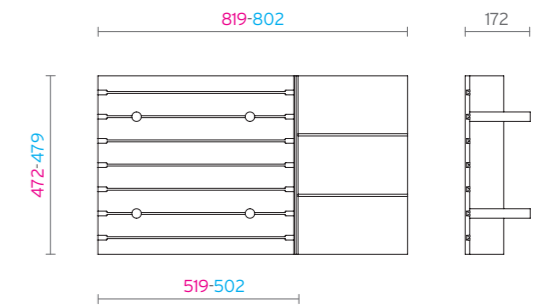
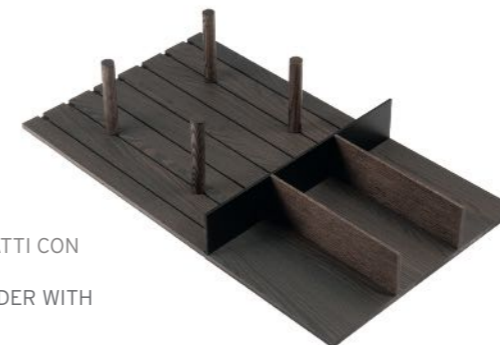

FILO DISPENSA
FILO PULL OUT

90

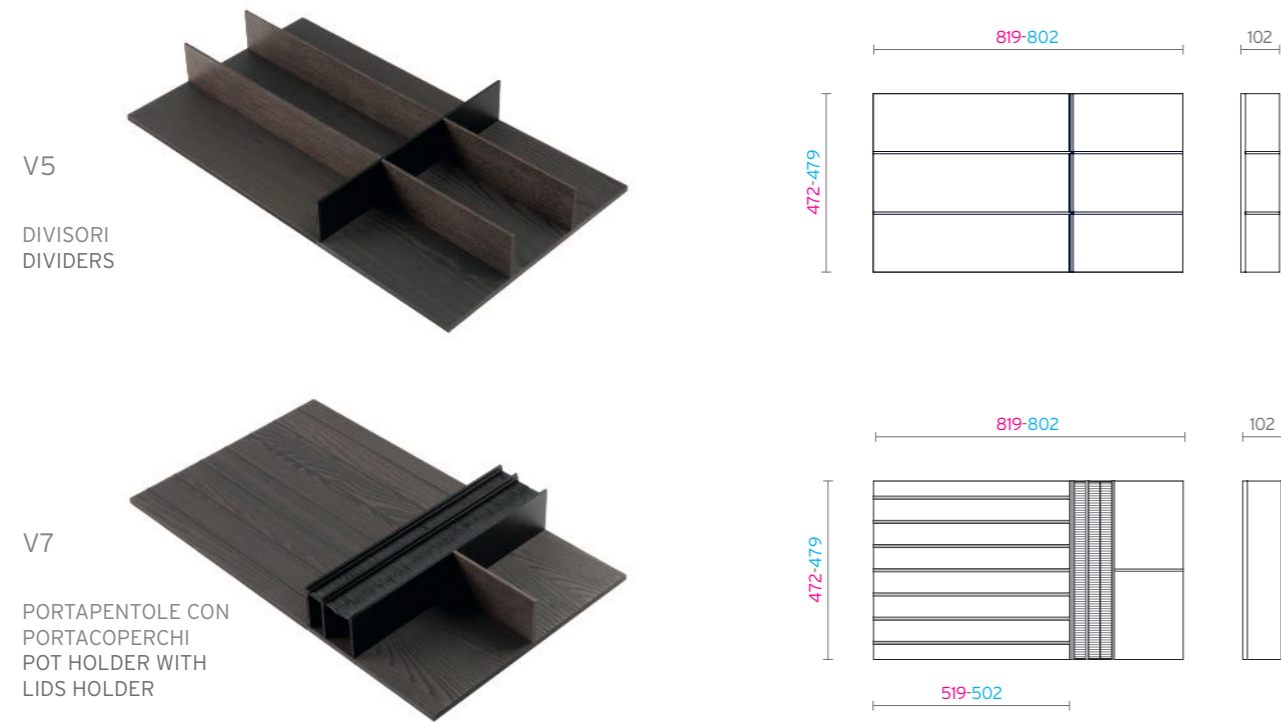

FILO DISPENSA
FILO PULL OUT

105

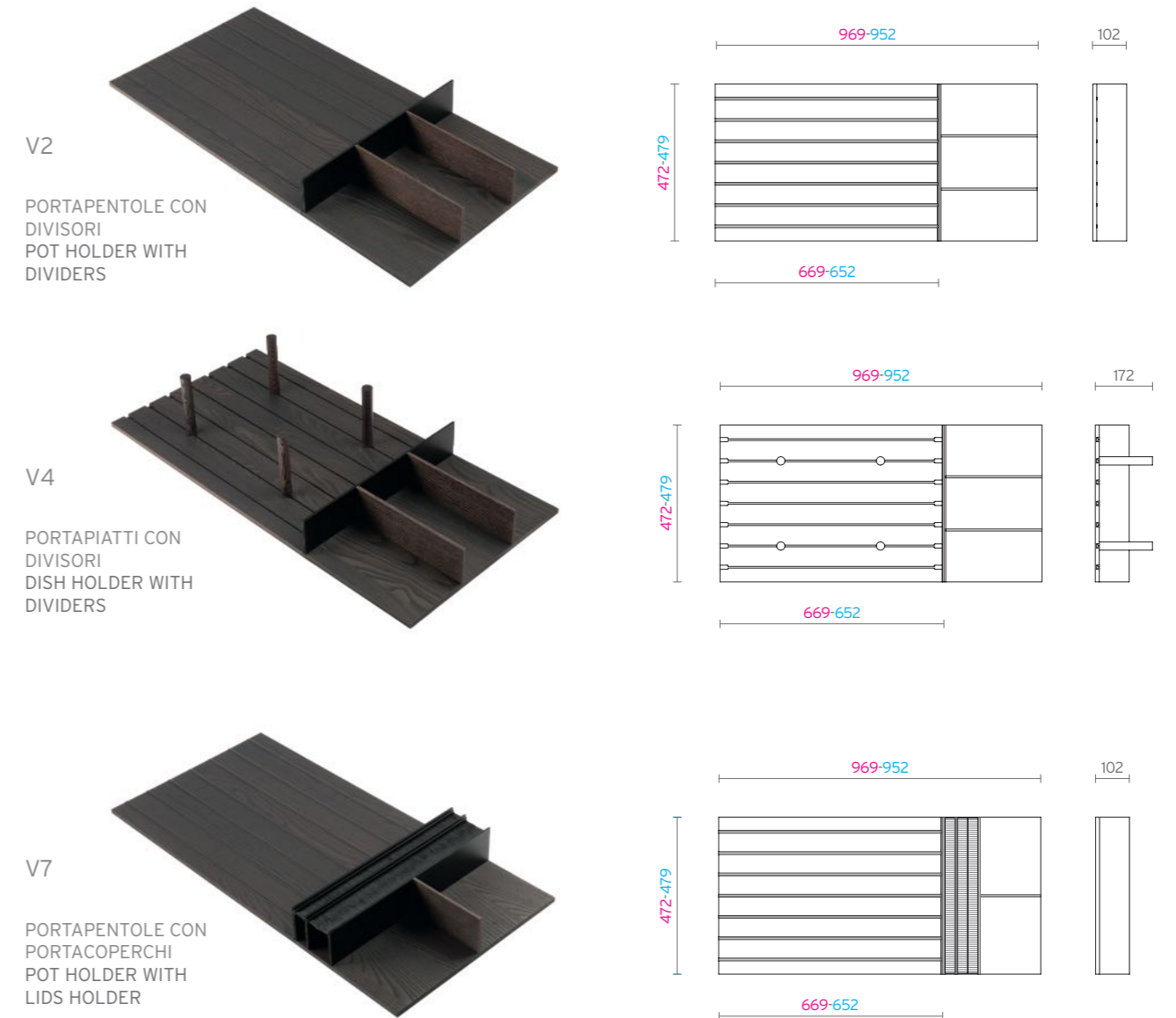

FILO DISPENSA FILO PULL OUT

120

V2		
PORTAPENTOLE CON DIVISORI POT HOLDER WITH DIVIDERS		
V4		
PORTAPIATTI CON DIVISORI DISH HOLDER WITH DIVIDERS		
V5		
DIVISORI DIVIDERS		
V7		
PORTAPENTOLE CON PORTACOPERCHI POT HOLDER WITH LIDS HOLDER		





ESEMPI DI CONFIGURAZIONE FILO DISPENSA
 CONFIGURATIONS EXAMPLES FOR FILO PULL OUT



ESEMPI DI CONFIGURAZIONE FILO DISPENSA
 CONFIGURATIONS EXAMPLES FOR FILO PULL OUT

Dai cassetti
al mobile colonna una
rivoluzione degli spazi.

From drawers to columns
a revolution of spaces.

FRAME

L'ambiente cucina si sta evolvendo verso nuove forme abitative, in risposta agli stili di vita contemporanei. La classica cucina, concepita con ripiani e pensili, lascia il posto a una distribuzione più destrutturata e al tempo stesso inclusiva.

Al centro troviamo un'isola attrezzata con il piano cottura, lavello ed elettrodomestici abbinati, mentre lungo le pareti i mobili diventano colonne che possono nascondere completamente, o lasciare a vista, gli elementi posti sulle differenti mensole.

In questo contesto nasce Frame, il nuovo sistema di accessori interni per le colonne cucina, progettato per ottenere grande funzionalità, libertà e possibilità di sperimentare nuove modalità di organizzazione.

Frame è composto da un telaio in alluminio verniciato, abbinato a una serie di accessori dedicati, realizzati con materiali pregiati, speciali finiture antigraffio e curati nei minimi dettagli.

La collezione è pensata per differenti funzionalità. Ogni ripiano assolve a una funzione specifica: si passa dal portapiatti al portabicchieri, portabottiglie, portacalici, portapentole, portacoperchi, fino alla classica mensola.

Frame è disponibile in due profondità, una standard e una ridotta, più specifica per gli strumenti da cucina della zona preparazione. Questa seconda versione può anche essere predisposta per contenere prese Schuko e USB.

Gli elementi possono essere mixati tra loro per ottenere la massima libertà e personalizzazione. A completamento è possibile aggiungere, ad alcuni di questi elementi, gli accessori della linea Fit/Filo.

Kitchen environments are evolving towards new living conditions, in response to the different styles of contemporary life. The classic kitchen, thought with shelves and kitchen cabinets, gives place to a more destructured and, at the same time, inclusive distribution.

At the centre we find a kitchen island with cooktop, sink and domestic appliances combined, while along the wall furniture becomes columns, which can completely hide all the elements or leave them exposed on the different shelves.

In this context Frame is born, the new system of internal accessories for kitchens columns, designed to obtain great functionality, freedom and the possibility to experience new ways of organization.

Frame is made of a painted aluminium frame, combined to a series of dedicated accessories, realized with fine materials, special anti-scratch finishes. Careful attention is paid to every minimum detail.

The collection is thought for different functionalities. Each shelf has a specific function: we go through the dish holder, the glass holder, the bottle holder, the wine glass holder, the pot holder, the lid holder, up to the classic shelf.

Frame is available in two different depths, the standard one and a reduced one, more specific for kitchen's tools from the food preparation area. This second version can also be equipped with Schuko sockets and USB ports.

The different elements can be mixed together to obtain the maximum freedom and customization. To complete Frame it is possible to add, to some of these elements, the accessories from the series Fit and Filo.

FRAME TELAIO CONTENITORE CONTAINER FRAME



Il telaio del sistema Frame, disponibile in due profondità da 500mm e 260mm, è una struttura che permette di comporre tutte le configurazioni secondo le proprie specifiche esigenze.

Il sistema possiede come opzione la possibilità di installare un'illuminazione formata da una barra led dual color che viene inserita all'interno dei profili e che può essere posizionata sia nella parte anteriore, sia nella parte posteriore sia su entrambi i lati.

Frame's containing structure, available with a depth of 500mm or 260mm, allows for the creation of different configurations, to align with everyone's needs.

The structure has the possibility to install a dual color LED lighting, which is incorporated inside the profiles and can be positioned on the front side, back side or on both sides of the structure.



FRAME TELAIO CONTENITORE 500
CONTAINER FRAME 500

60

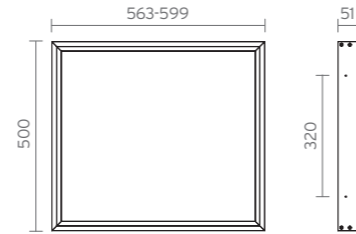

75

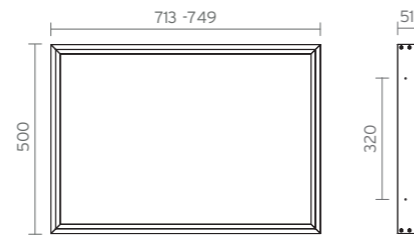

90

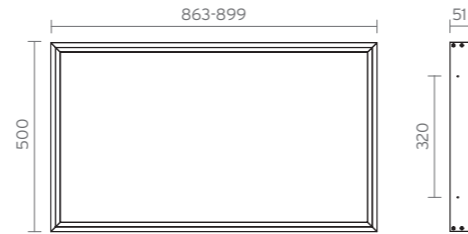

105

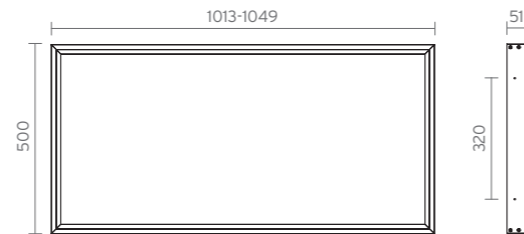

120

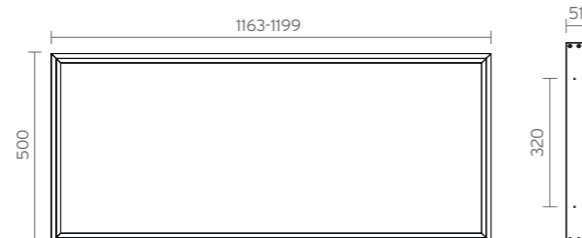

FRAME TELAIO CONTENITORE 260
CONTAINER FRAME 260

90

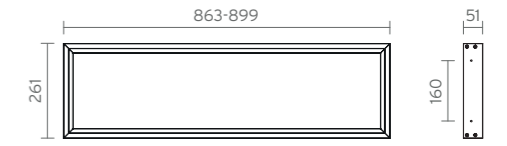

120

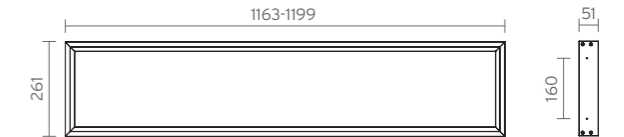

FRAME TELAIO CONTENITORE CONTAINER FRAME

500

260

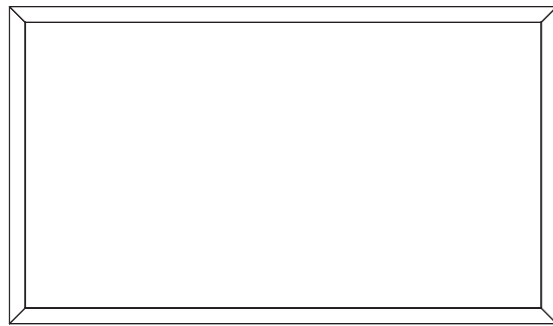

SENZA LUCI
WITHOUT LIGHTS

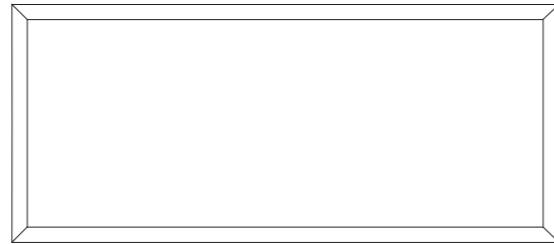

SENZA LUCI
WITHOUT LIGHTS



LUCE SINGOLA ANTERIORE O POSTERIORE
SINGLE FRONT OR BACK LIGHT



LUCE SINGOLA ANTERIORE O POSTERIORE
SINGLE FRONT OR BACK LIGHT

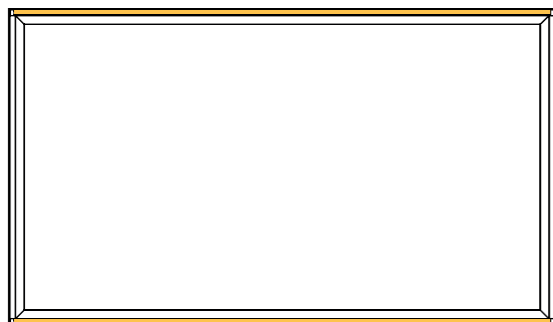

LUCE DOPPIA ANTERIORE E POSTERIORE
DOUBLE LIGHT

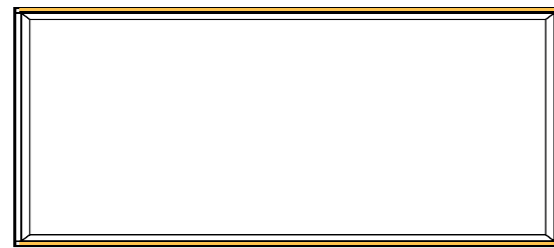

LUCE DOPPIA ANTERIORE E POSTERIORE
DOUBLE LIGHT

SCHEMA ASSEMBLAGGIO ASSEMBLY SCHEME

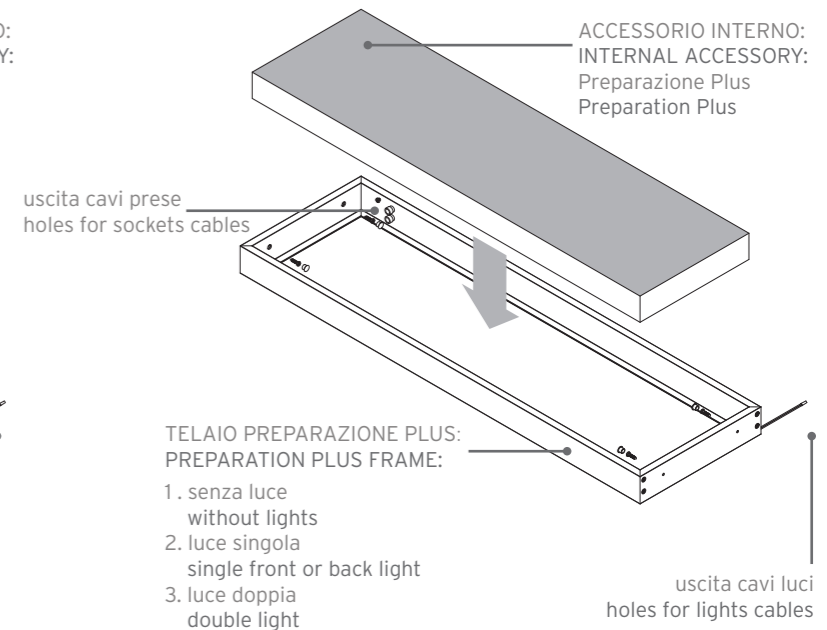
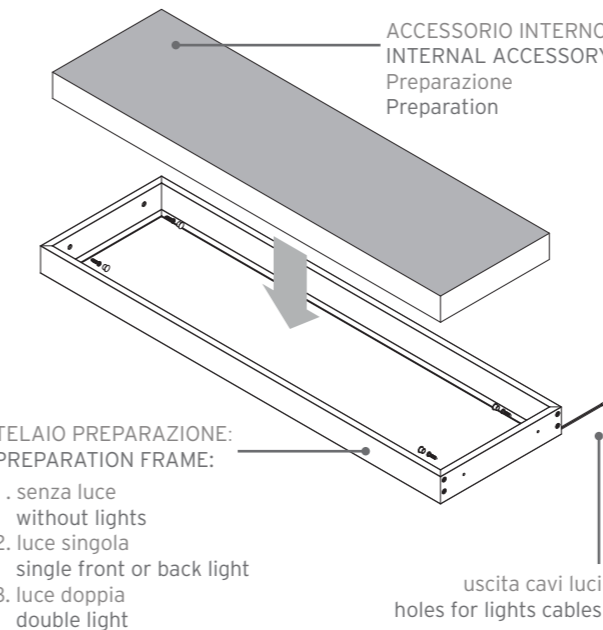
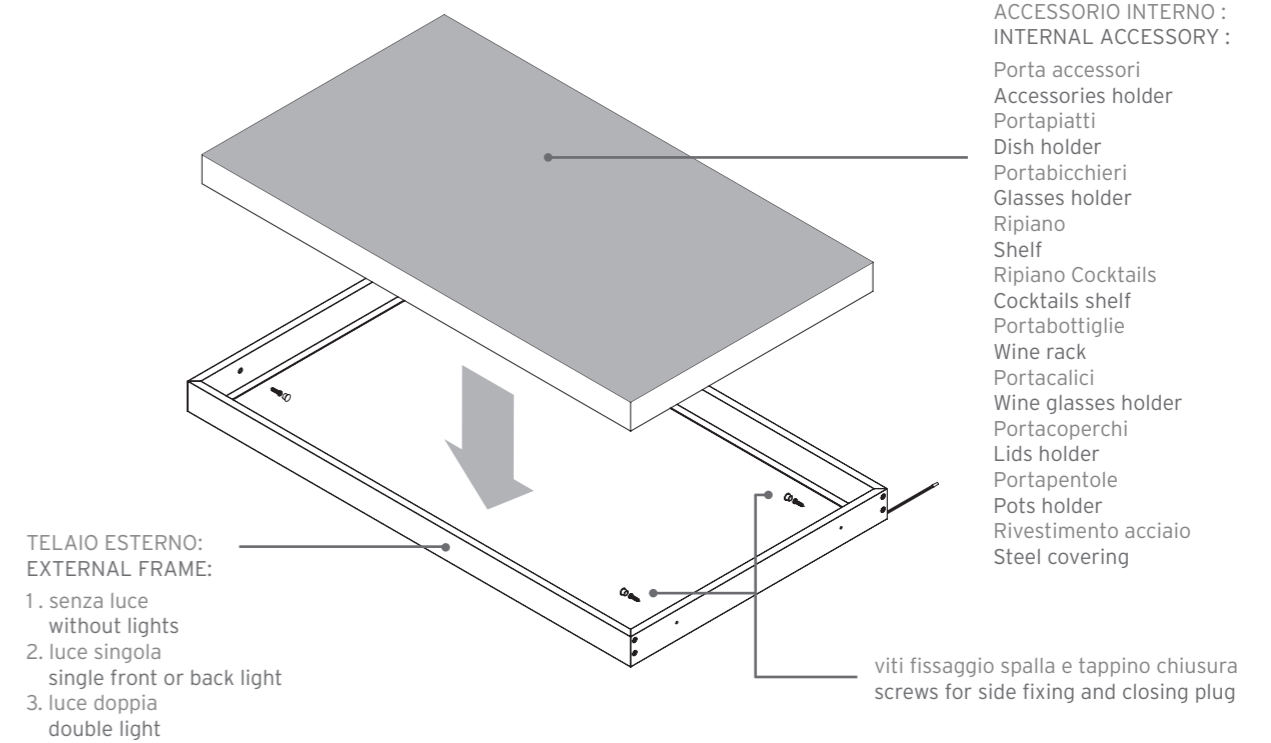

Dopo aver fissato il telaio con le apposite viti alle spalle del mobile e collegati i cavi, nel caso in cui fossero presenti le luci, inserire l'accessorio appoggiandolo all'interno.

After fixing the frame to the back of the cabinet using the screws provided and connecting the cables if lights are present, insert the accessory by placing it on the inside.

Nota: per via della presenza delle prese e delle relative uscite cavi, il ripiano preparazione PLUS può essere montato esclusivamente su un telaio "preparazione PLUS".



FRAME ACCESSORI CONTENITORI FRAME INTERIORS ACCESSORIES



All'interno del telaio Frame è possibile inserire 13 diversi contenitori e mensole, ciascuno con funzionalità specifiche. Sono presenti ripiani per riporre attrezzi da cucina, piatti, bicchieri, pentole, coperchi e bottiglie, affiancati da ripiani dedicati alla preparazione di cibo e cocktail.

The system can be equipped with 13 different containers and shelves, each of them with a specific functionality. The accessories allow for the organization of kitchen tools, dishes, glasses, pots, lids and bottles, along with other accessories designed for the preparation of food and cocktails.



PORTA ACCESSORI
ACCESSORIES HOLDER

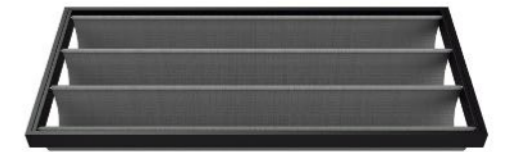

PORTACOPERCHI
LIDS HOLDER



PORTAPIATTI
DISH HOLDER



PORTAPENTOLE
POTS HOLDER

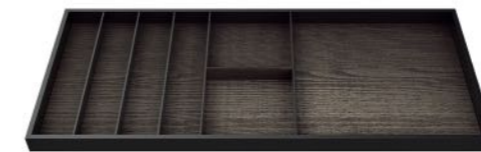

PORTABICCHIERI
GLASSES HOLDER



RIPIANO
SHELF



RIPIANO COCKTAILS
COCKTAILS SHELF



PREPARAZIONE V1 - V2
PREPARATION V1 - V2

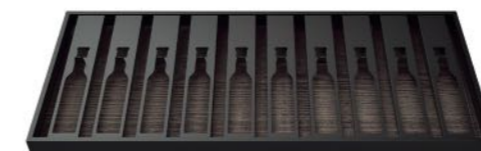

PORTABOTTIGLIE
WINE RACK



PREPARAZIONE PLUS V1 - V2
PREPARATION PLUS V1 - V2



PORTACALICI
WINE GLASSES HOLDER



RIVESTIMENTO ACCIAIO
STELL COVERING

FRAME PORTA ACCESSORI FRAME ACCESSORIES HOLDER



Il ripiano porta accessori è pensato per l'organizzazione di posate, utensili da cucina, tovaglioli e oggetti vari legati alla preparazione della tavola. Questo ripiano può essere arricchito con gli accessori opzionali Fit/Filo di tipo A e B.

The accessories holder is designed for the organization of cutlery, cooking tools, napkins and various objects dedicated to the preparation of the dining table. This shelf can be equipped with accessories A and B from the Fit/Filo series.

60

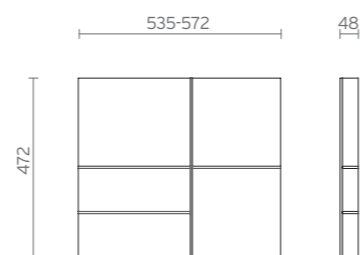

FRAME PORTA ACCESSORI FRAME ACCESSORIES HOLDER

75

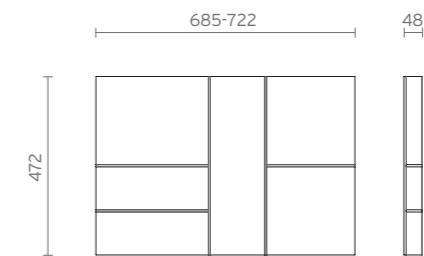
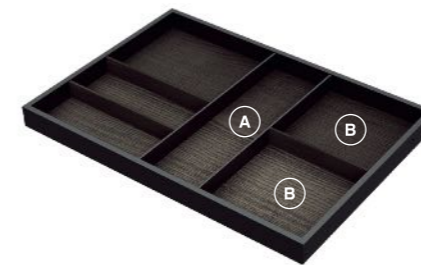

90

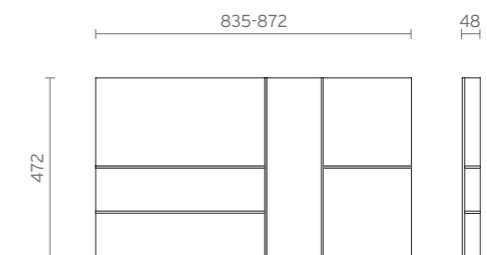
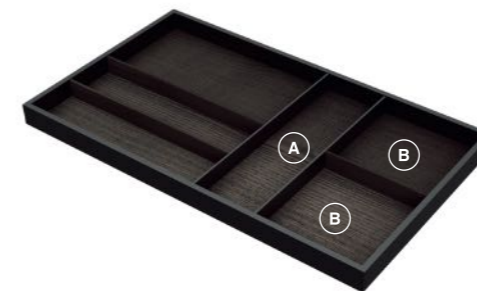

105

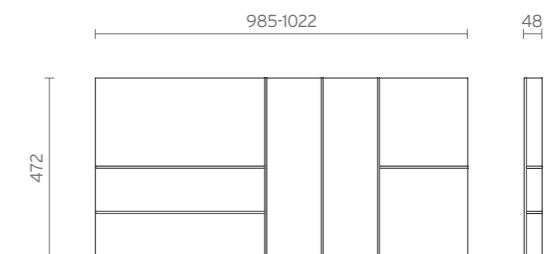

120

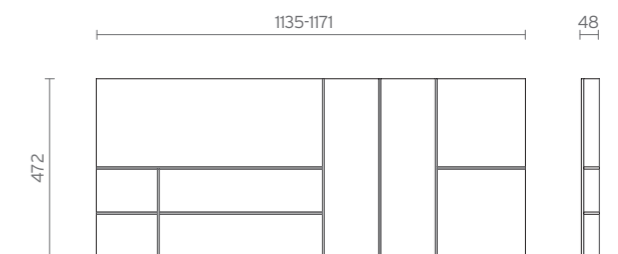

FRAME PORTAPIATTI FRAME DISH HOLDER



Il ripiano portapiatti permette una disposizione ordinata di piatti piani, fondi e da dessert, mantenendoli sempre pronti all'uso. Pensato inoltre per evitare lo sfregamento tra i piatti.

The dish rack allows for an orderly arrangement of the different dining plates, keeping them ready for use. Thought to avoid rubbing between plates and to reduce weight during moving.

60

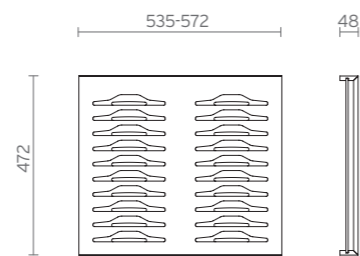

FRAME PORTAPIATTI FRAME DISH HOLDER

75

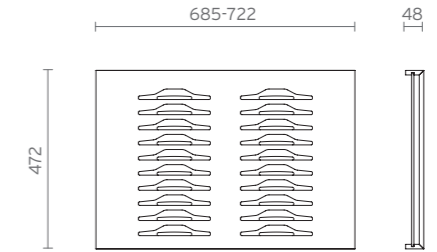

90

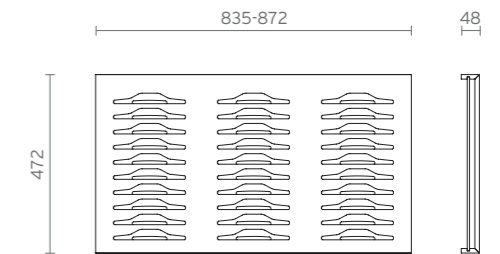

105

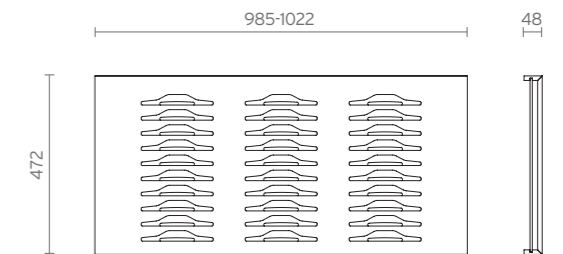
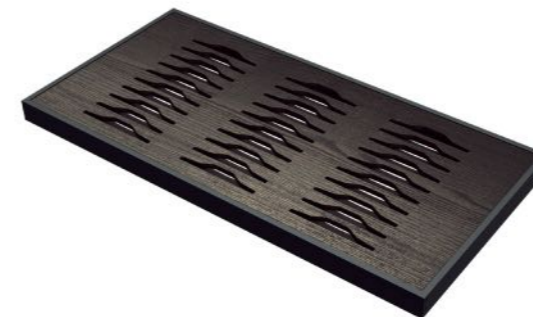

120

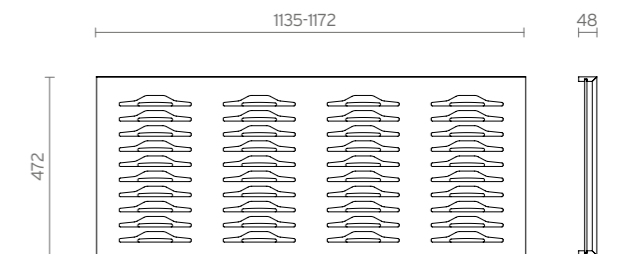
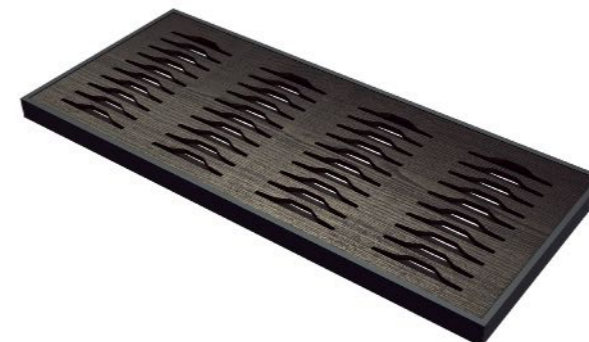

FRAME PORTABICCHIERI FRAME GLASS HOLDER



Il ripiano portabicchieri possiede una serie di divisori verticali per la disposizione ordinata dei vari bicchieri da tavola. Permette inoltre l'organizzazione di tovaglioli, tovaglie e canovacci da cucina. Questo ripiano può essere arricchito con gli accessori opzionali Fit/Filo di tipo A e B.

The glasses holder is designed with a series of vertical spaces, allowing for the placement of the different dining glasses. It also allows for the organization of napkins, tablecloths and towels. This shelf can be equipped with accessories A and B from the Fit/Filo series.

60

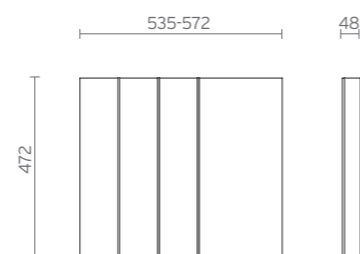

FRAME PORTABICCHIERI FRAME GLASS HOLDER

75

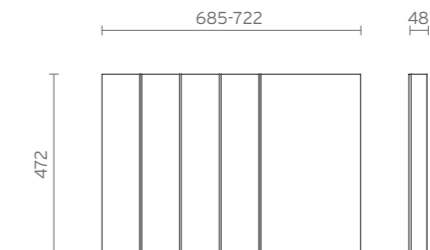

90

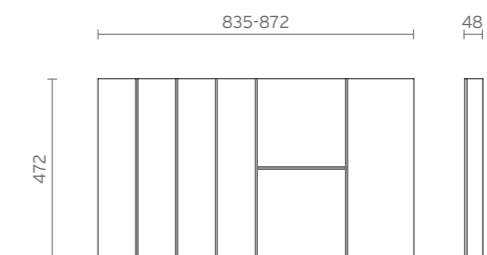

105

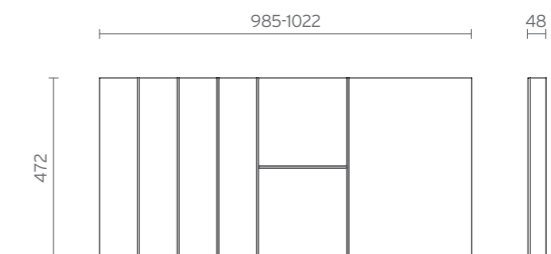

120

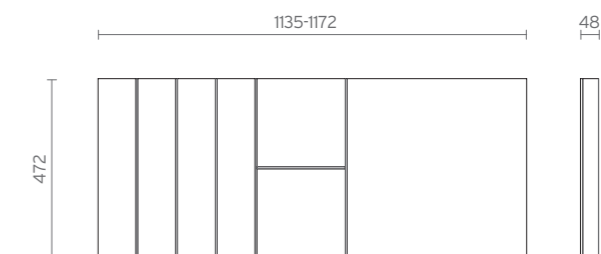

FRAME RIPIANO COCKTAILS FRAME COCKTAILS SHELF



Pensato per la preparazione di cocktail e aperitivi, permette di riporre gli utensili necessari, in aggiunta a bicchieri speciali, bottiglie di alcolici, succhi e soft drinks. Questo ripiano può essere arricchito con gli accessori opzionali Fit/Filo di tipo A e B, in particolare con il set cocktail e il set vino.

Designed for the preparation of cocktails and appetizers, it allows for the organization of cocktail tools, special glasses, bottles of spirits, fruit juices and soft drinks. This shelf can be equipped with accessories A and B from the Fit/Filo series, especially with cocktail set and wine set.

60

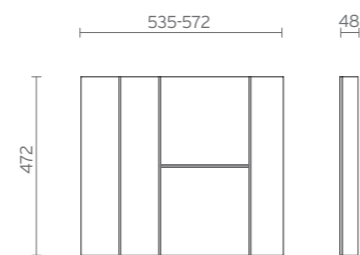

FRAME RIPIANO COCKTAILS FRAME COCKTAILS SHELF

75

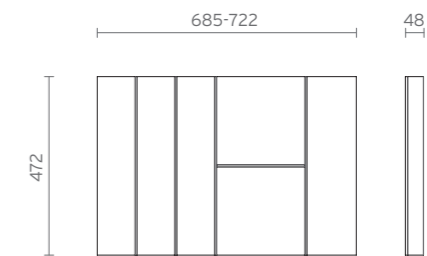

90

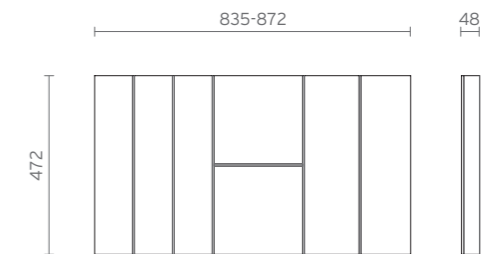

105

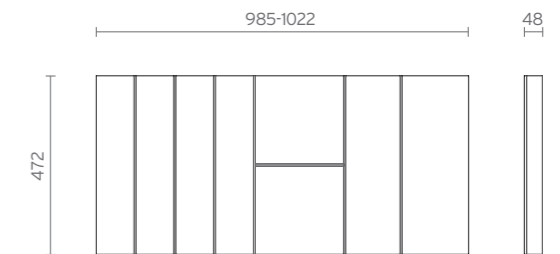
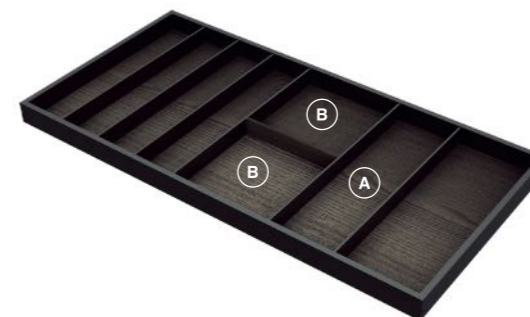

120

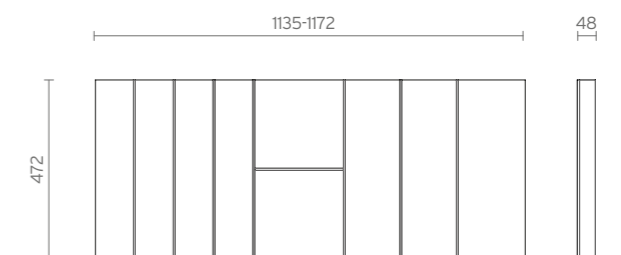

FRAME PORTABOTTIGLIE FRAME BOTTLE HOLDER



Il ripiano portabottiglie è progettato per la conservazione del vino, permettendo una disposizione ordinata delle bottiglie e mantenendole alla giusta inclinazione di 4°.

The wine rack is designed for the storage of wine bottles, allowing for an orderly arrangement and keeping the bottles at the proper inclination of 4°.

60

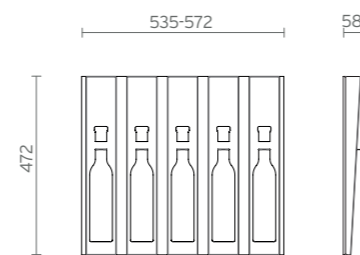

FRAME PORTABOTTIGLIE FRAME BOTTLE HOLDER

75

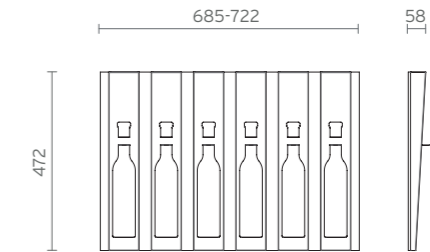

90

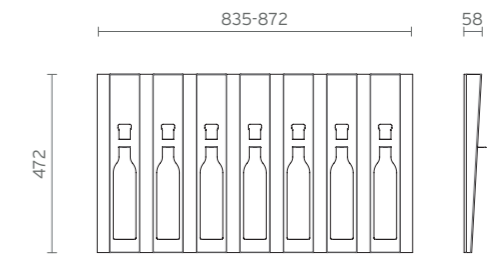

105



120

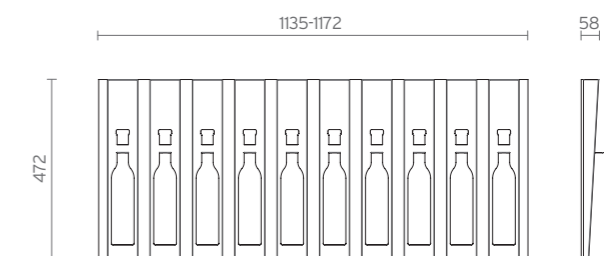

FRAME PORTACALICI FRAME GLASS WINE HOLDER



Elegante, pratico, sicuro, è dotato di feltrini antigraffio per non danneggiare lo stelo e la base del calice. Ideale per l'ossigenazione dei bicchieri a calice.

Elegant, practical and safe, it includes anti-scratch felt pads to avoid any damage to the stem or the base of the glasses. Ideal for the oxygenation of wine glasses.

60

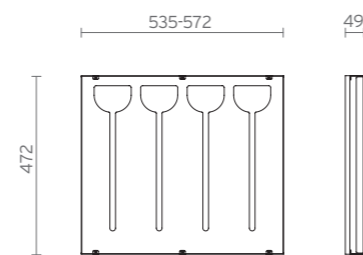

FRAME PORTACALICI FRAME GLASS WINE HOLDER

75

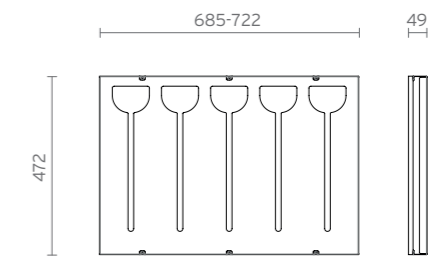

90

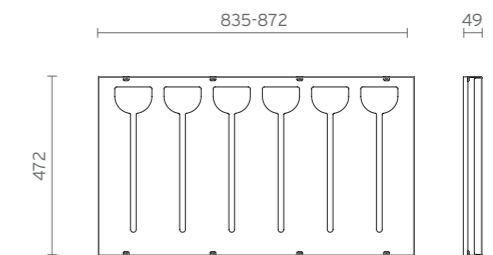

105

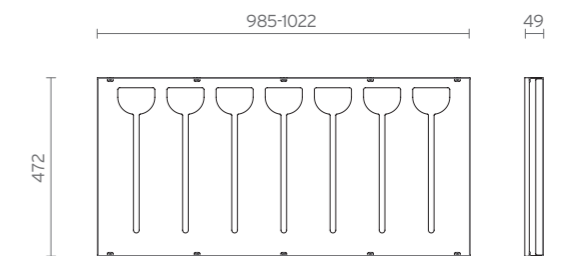

120

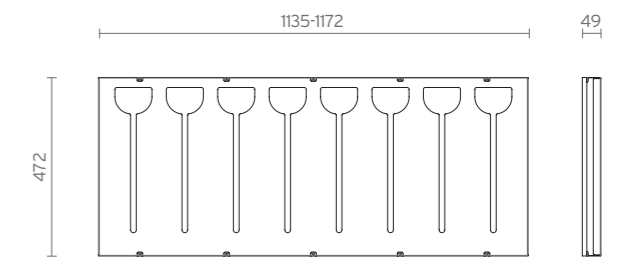

FRAME PORTACOPERCHI FRAME LIDS HOLDER

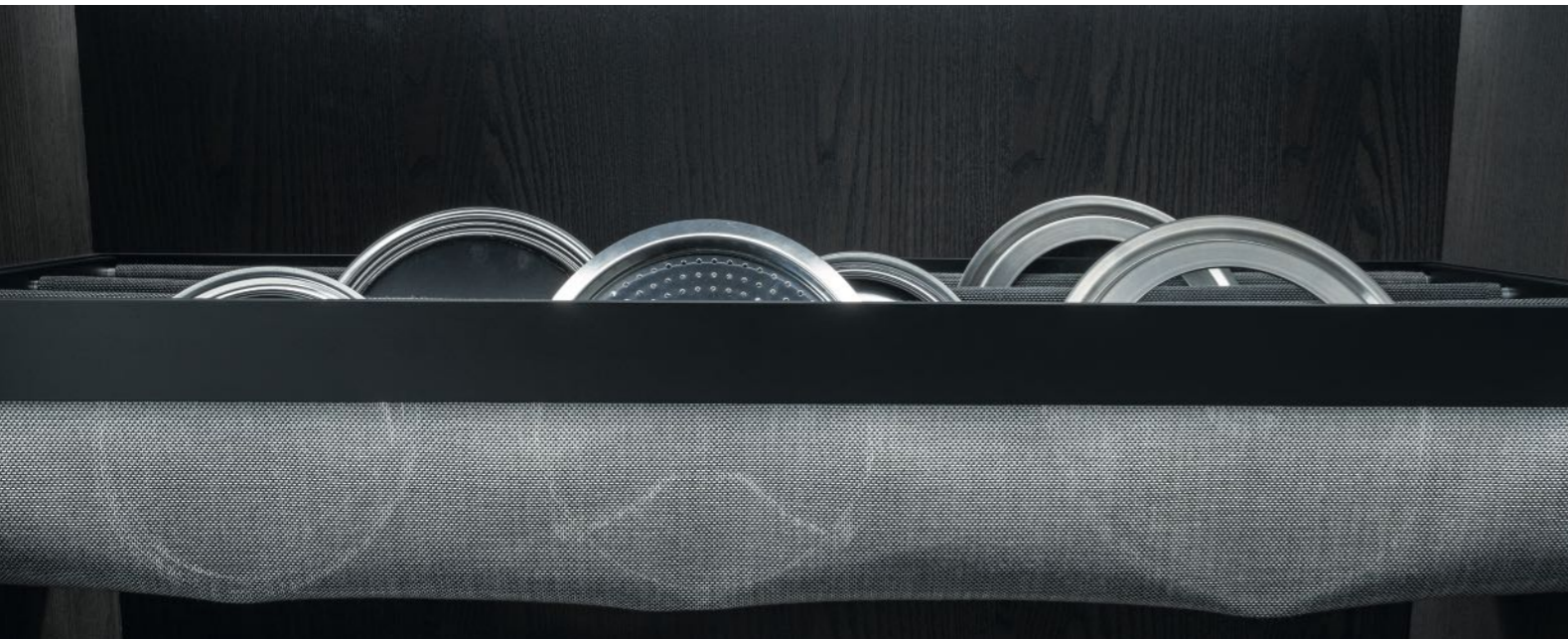

Il ripiano portacoperchi è dotato di pratiche culle in tessuto per una disposizione ordinata dei coperchi di pentole e padelle, agevolandone il prelievo e il deposito ed evitando la formazione di graffi o ammaccature.

The lids holder is designed with multiple fabric grooves for an orderly placement of pans and pots lids, allowing for an easier storage and avoiding the formation of scratches and dents.

60

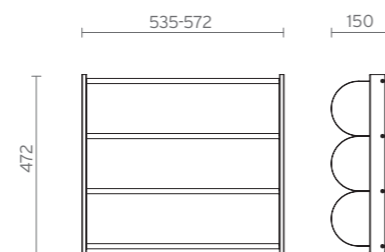

FRAME PORTACOPERCHI FRAME LIDS HOLDER

75

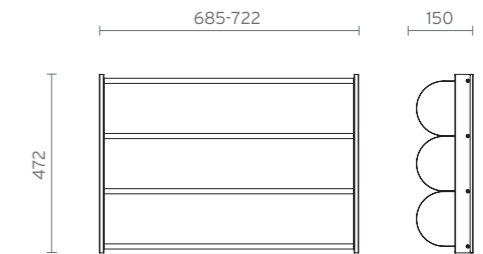

90

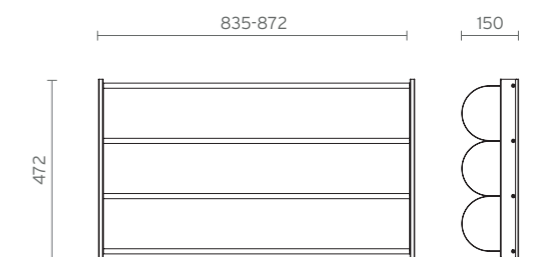

105

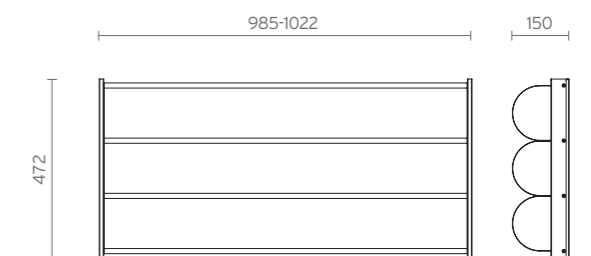

120

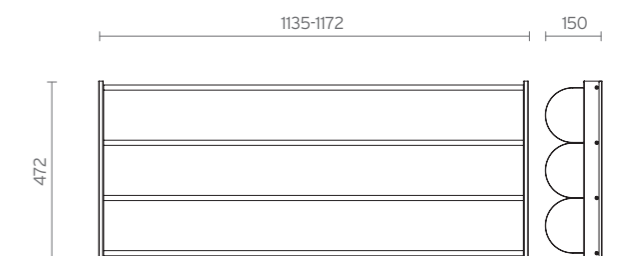





FRAME PORTAPENTOLE FRAME POT HOLDER



Il ripiano portapentole è dotato di guarnizioni antiscivolo e antigraffio, per un posizionamento stabile e sicuro delle varie pentole da cucina.

The pots holder is equipped with non-slip and anti-scratch seals, for a stable and safe placement of the different cooking pots.

60

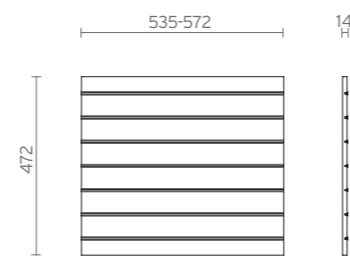

FRAME PORTAPENTOLE FRAME POT HOLDER

75

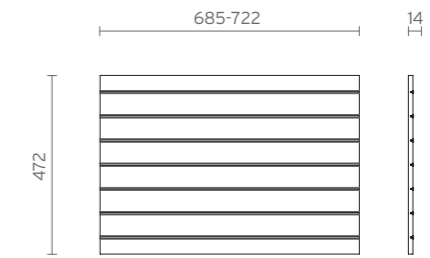

90

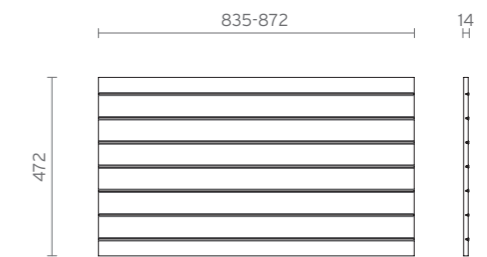

105

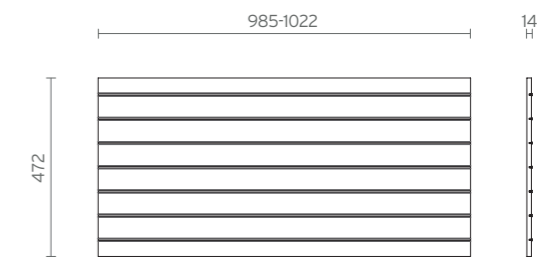

120

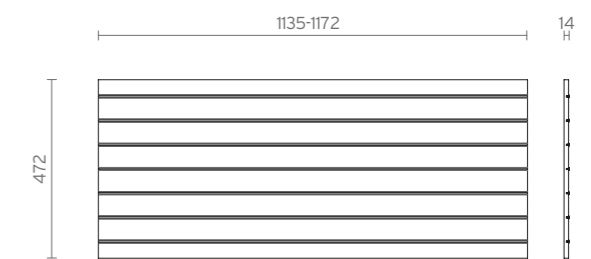

FRAME RIPIANO FRAME SHELF



Il ripiano semplice permette un posizionamento libero di ciotole, pirofile, vassoi e contenitori da cucina, fornendo inoltre da superficie di lavoro per la preparazione dei cibi. The shelf allows for a free disposition of bowls, baking dishes, trays and cooking containers, also providing a working surface for the preparation of food.

60

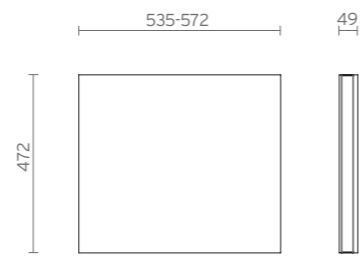

FRAME RIPIANO FRAME SHELF

75



90

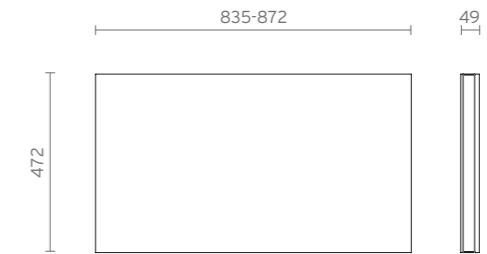

105

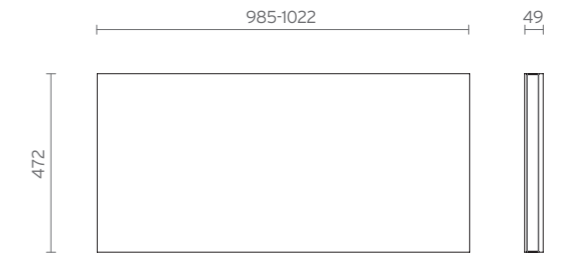

120

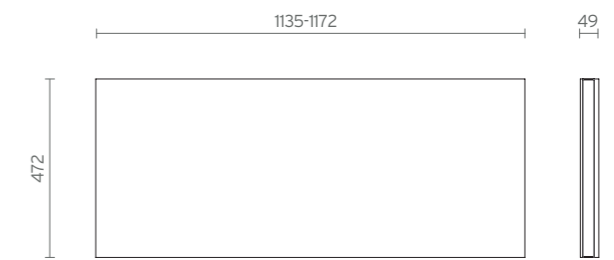

FRAME PREPARAZIONE FRAME PREPARATION



Pensata per il vano con profondità 260mm, il ripiano preparazione è indicato per tutte le situazioni in cui si vuole mantenere libero lo spazio sovrastante il piano di lavoro, avendo comunque a disposizione un contenitore per i differenti attrezzi da cucina. Questo ripiano può essere arricchito con gli accessori opzionali Fit/Filo di tipo A e B.

Available for the 260mm deep frame only, the preparation shelf is designed to keep as much free space as possible above the working surface, still allowing for the organization of different cooking tools. This shelf can be equipped with accessories A and B from the Fit/Filo series.

FRAME PREPARAZIONE FRAME PREPARATION

90

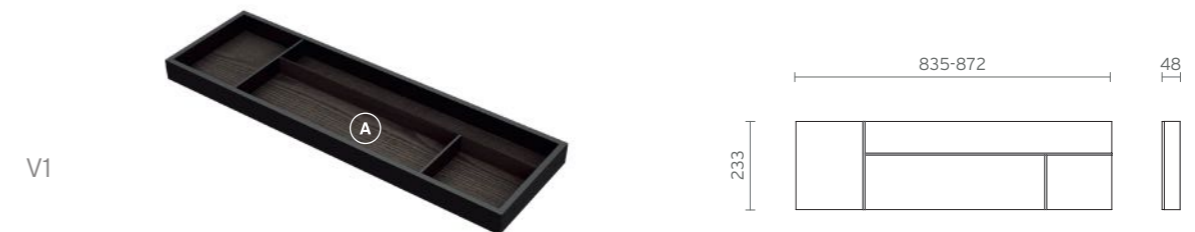

120

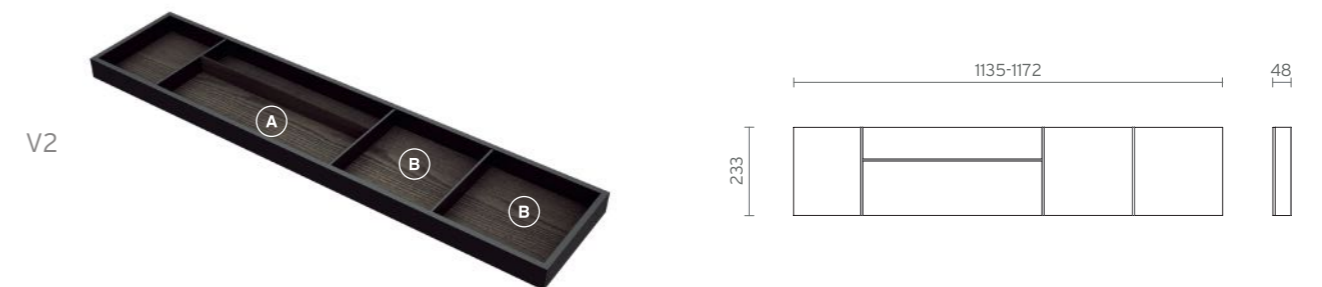
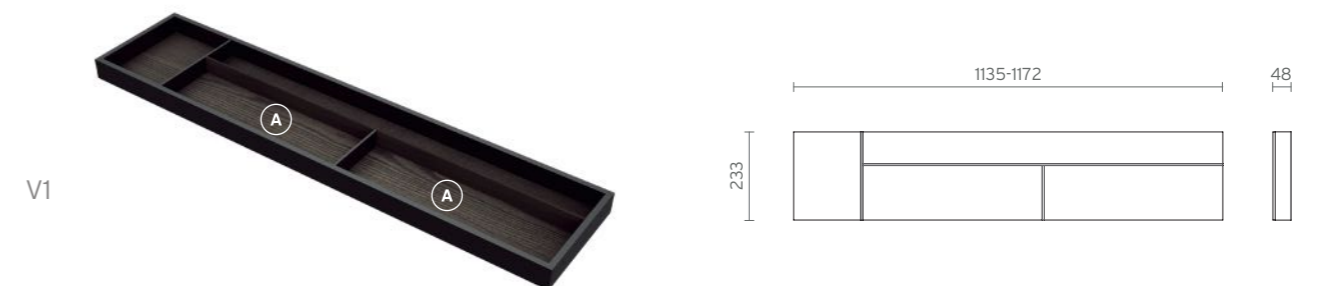

FRAME PREPARAZIONE PLUS FRAME PREPARATION PLUS



Il ripiano preparazione Plus mantiene invariate le caratteristiche del preparazione standard, aggiungendo però una presa Schuko e due porte USB per alimentare piccoli elettrodomestici o dispositivi elettronici.

The preparation Plus keeps the same characteristics of the standard preparation shelf, adding a Schuko socket and two USB ports to power small household appliances or other electronic devices.



FRAME PREPARAZIONE PLUS FRAME PREPARATION PLUS

90

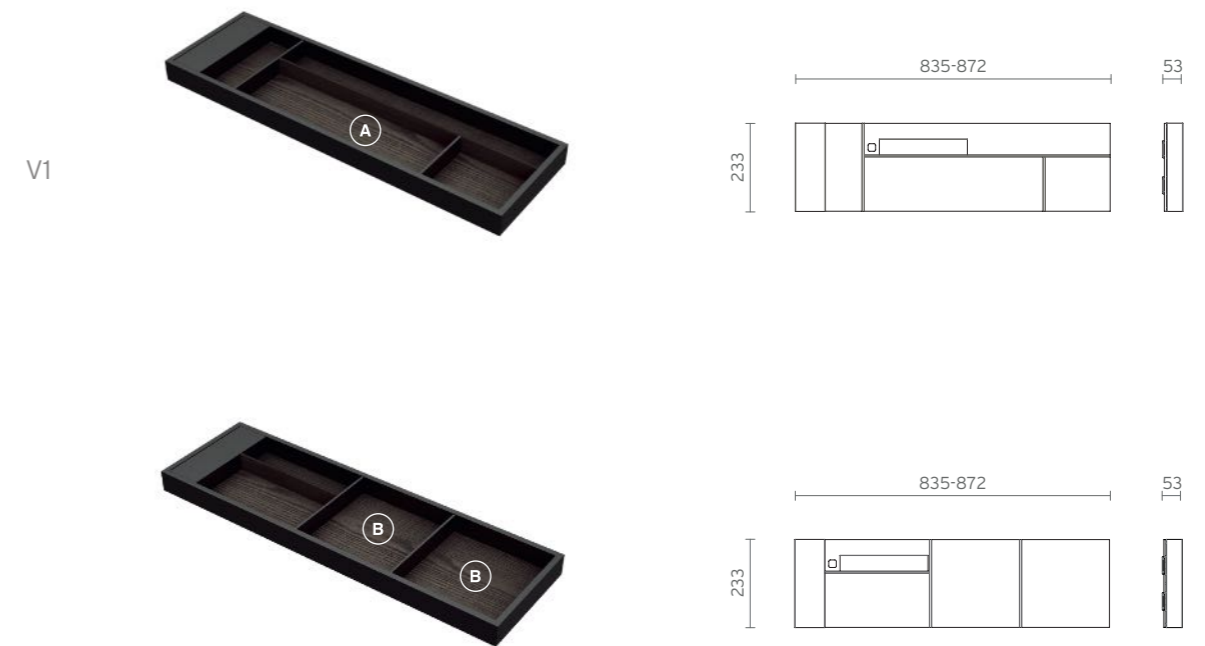

120

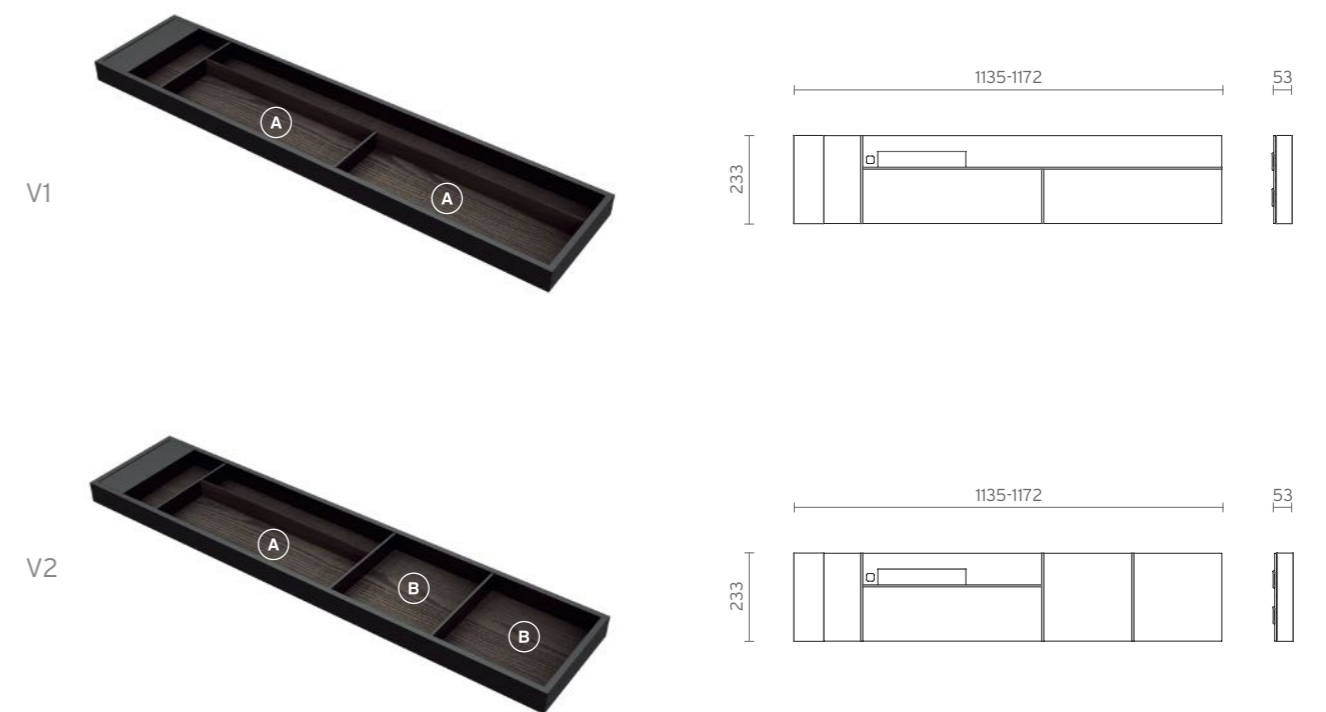

FRAME RIVESTIMENTO ACCIAIO FRAME STEEL COVERING

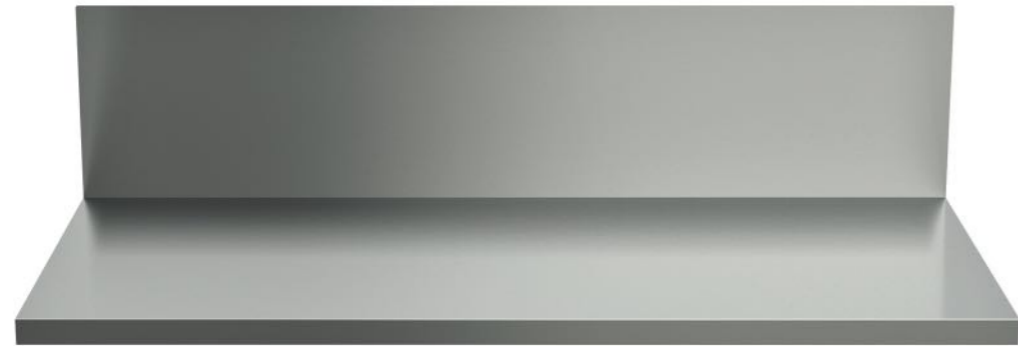

Pensato a completamento della zona preparazione, funge da copertura del piano di lavoro al di sotto delle mensole a profondità 260 mm, per facilitarne la pulizia dopo l'uso. Viene realizzato su misura per il cliente.

Designed to complement the preparation area, it covers the work surface underneath the 260mm preparation shelves, for an easier cleaning process after use. Tailor made on the customer's specifications.

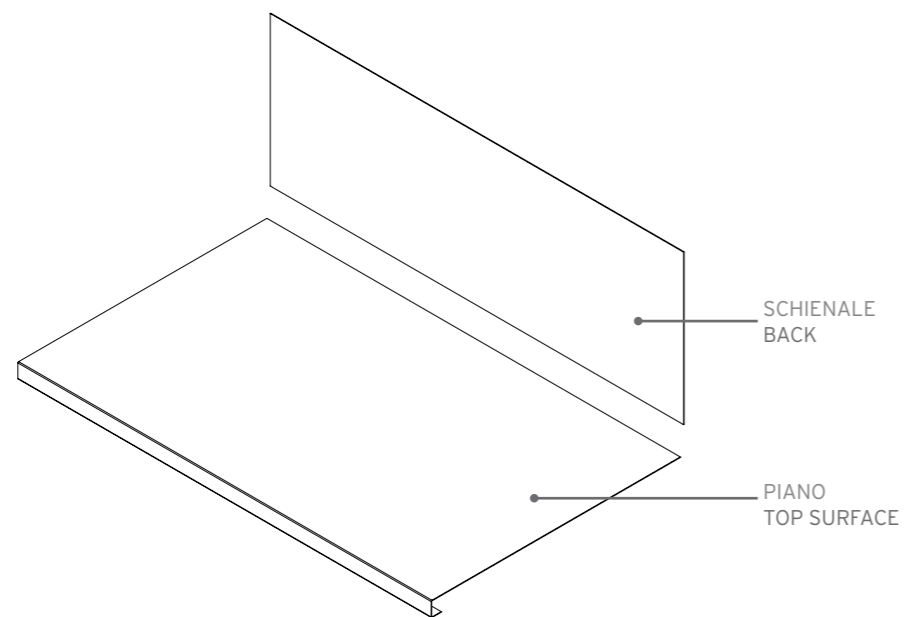

N.B. Guarnizioni e materiali per il fissaggio sono inclusi nel prodotto.
N.B. Gaskets and fasteners are included in the product





ESEMPIO DI CONFIGURAZIONE COLONNA DEDICATA ALLA PREPARAZIONE,
 CON MENSOLE A PROFONDITÀ RIDOTTA E RIVESTIMENTO DEL PIANO IN ACCIAIO
 CONFIGURATION EXAMPLE OF A PREPARATION COLUMN,
 WITH REDUCED DEPTH SHELVES AND STEEL COVERING OF THE WORK SURFACE



ESEMPIO DI CONFIGURAZIONE COLONNA DEDICATA ALLA PREPARAZIONE,
 CON MENSOLE A PROFONDITÀ RIDOTTA E RIVESTIMENTO DEL PIANO IN ACCIAIO
 CONFIGURATION EXAMPLE OF A PREPARATION COLUMN,
 WITH REDUCED DEPTH SHELVES AND STEEL COVERING OF THE WORK SURFACE





DETTAGLIO RIPIANO COCKTAILS
COCKTAILS SHELF DETAIL



DETTAGLIO PREPARAZIONE RIPIANO V1 E V1 PLUS
PREPARATION V1 E V1 PLUS SHELVES DETAILS

ACCESSORI

Troviamo
uno spazio perfetto per
ogni oggetto da cucina.

We find
a perfect place for
every single kitchen's tool.

Dove lo metto?

Abbiamo pensato a tutto!

Quando entriamo in una cucina ci accorgiamo che tanti piccoli oggetti di utilizzo quotidiano, impiegati nella preparazione di cibi e bevande, non hanno un collocamento specifico. Spesso vengono posizionati sul piano della cucina, appesi a ganci o calamite, riposti su mensole e ripiani, oppure sparpagliati all'interno dei cassetti.

Per chi desidera organizzare e ottimizzare gli spazi, ogni oggetto potrà avere il suo giusto collocamento.

Il sistema FIT e FILO è arricchito da una serie di speciali accessori, posizionabili in compartimenti specifici dei portaposate e delle dispense, studiati per contenere molti degli oggetti che altrimenti non avrebbero un loro spazio definito.

Si tratta di coltelli, pellicole per alimenti, cialde per caffè, portaspezie, set per la preparazione degli impasti, set per i condimenti. E ancora, set dedicati alla preparazione di cocktail e vini, alla consumazione di formaggi e sushi, appositi spazi per riporre taglieri, portabottiglie, portabicchieri, sino allo scolapiatti.

La collezione FRAME, analogamente, è stata studiata per contenere i medesimi accessori, disposti all'interno di alcuni dei ripiani nel mobile colonna.

Nei sistemi Fit e Filo è previsto inoltre un compensatore di profondità, che viene utilizzato all'interno dei cassetti con profondità 60 cm. Può essere abbinato al fondo dei portaposate o delle dispense. Il compensatore è disponibile per cassetti da 45, 60, 75, 90, 105 e 120 cm di larghezza.

Where do I put it?

We have thought of everything!

When we walk into a kitchen we realize that a lot of small objects, daily used for food and drink preparation, don't have a specific place where to be placed. They are often laid onto the kitchen's worktop, hung on hooks or magnets, put on shelves or just spread inside the drawers.

For those who desire to organize and optimize all the spaces, every object will have its right placement.

The FIT and FILO system is enriched by a series of special accessories that can be placed into specific cutlery and pull out's sectors, designed to contain some of those objects that otherwise wouldn't have a storage space.

Knives, cling films, coffee pots, spice containers, sets for dough preparations, condiments sets. And again, sets for cocktails and wine preparation, for cheese and sushi consumption, spaces for cutting boards, bottles holders, glasses holders and dish racks.

The FRAME collection, similarly, was designed to contain the same accessories, placed into some of the shelves inside the column.

A depth spacer is also provided for FIT and FILO systems, used inside drawers with a depth of 60cm. It can be used together with the cutlery inserts or the pull out. The spacer is available for drawers with widths of 45, 60, 75, 90, 105 and 120 cm.

A ACCESSORI PORTAPOSATE FIT - FILO e CONTENITORI FRAME
FIT - FILO CUTLERY INSERTS and FRAME CONTAINERS ACCESSORIES

**DIVISORIO A T
PARTITION T**

Progettato per dividere il vano accessori in tre comodi scomparti, dove riporre oggetti più piccoli.

Designed to divide the accessories compartment into three useful compartments, to contain smaller objects.

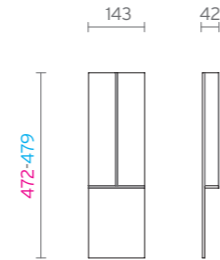

**PORTACOLTELLI
KNIVES HOLDER**

Elegante e funzionale, permette di riporre i coltelli in modo stabile e sicuro.

Elegant and functional, allows to store knives in a stable and safe way.

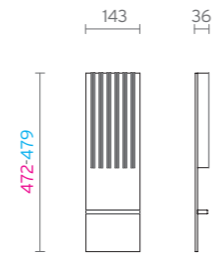

**PORTAPPELLICOLE
FILM HOLDER**

Pratico ed elegante doppio dispenser, con anima portatubo per facilitare la rotazione dei rotoli. I coperchi sono dotati di zigrinatura per il taglio e guarnizioni per ammortizzare la chiusura.

Practical and elegant double dispenser, with tube holder core to facilitate the rotation of the rolls. The lids are equipped with a serrated edge and seals to cushion the closing.

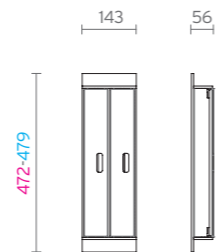

**PORTACIALDE
POD HOLDER**

Dispenser adatto a riporre fino a 30 cialde o capsule del caffè.

Dispenser where to store up to 30 coffee pods or capsules.

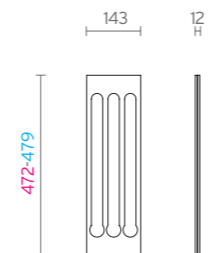

A ACCESSORI PORTAPOSATE FIT - FILO e CONTENITORI FRAME
FIT - FILO CUTLERY INSERTS and FRAME CONTAINERS ACCESSORIES

**PORTASPEZIE UNIVERSALE
UNIVERSAL SPICES CONTAINER**

Accessorio dove riporre barattoli di spezie, sali o alimenti di piccole dimensioni.

Accessory where to store jars of spices, salts or small food.

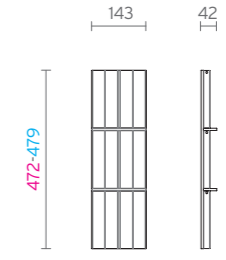

**PORTASPEZIE V
SPICES CONTAINER V**

Accessorio con barattoli in vetro dove riporre spezie, sali o alimenti di piccole dimensioni.

Accessory with glass jars where to store spices, salts or small food.

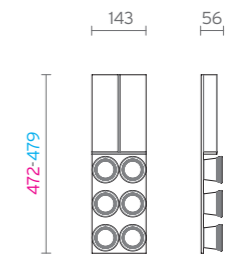

**PORTASPEZIE N
SPICES CONTAINER N**

Accessorio con barattoli in vetro e tappo di chiusura a vite dove riporre spezie, sali o alimenti di piccole dimensioni.

Accessory with glass jars and screw cap where to store spices, salts or small food.

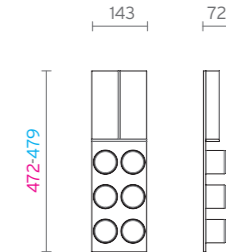

**SET PASTA FRESCA
FRESH PASTA SET**

Set dedicato alla preparazione di impasti. Comprende un innovativo mattarello ed una rotella taglia pasta.

Set dedicated to the preparation of dough. Includes an innovative rolling pin and a pasta cutter.

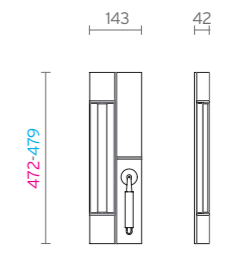

A ACCESSORI PORTAPOSATE FIT - FILO e CONTENITORI FRAME
FIT - FILO CUTLERY INSERTS and FRAME CONTAINERS ACCESSORIES

SET FORMAGGIO
CHEESE SET

Accessorio con un tagliere in ceramica, due coltelli da formaggio e uno spargimiele, per la preparazione e la consumazione di formaggi.

Accessory with a ceramic cutting board, two cheese knives and an honey dripper, for preparation and consumption of cheese.

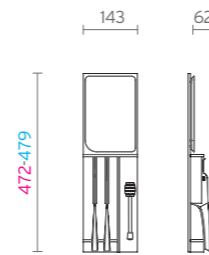

PORTABIBITE
DRINKS HOLDER

Progettato per ospitare fino a quattro bottigliette di bibite, succhi o alcolici di piccole dimensioni.

Designed to store up to four bottles of soft drinks, juices or small spirit bottles.

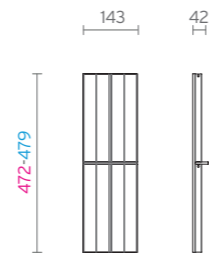

SET SUSHI
SUSHI SET

Set dedicato alla presentazione e al consumo di sushi. Contiene un tagliere in legno, bacchette, poggia bacchette e ciotoline per la salsa di soia.

Set dedicated to the presentation and consumption of sushi. It contains a wooden cutting board, chopsticks, chopsticks rests and small bowls for soy sauce.

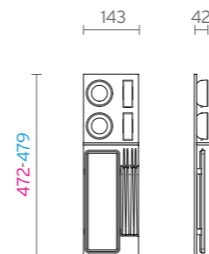

* N.B. La profondità di tutti gli accessori Frame misura 472mm

* N.B. The depth of all Frame accessories is 472mm

B ACCESSORI PORTAPOSATE FIT - FILO e CONTENITORI FRAME
FIT - FILO CUTLERY INSERTS and FRAME CONTAINERS ACCESSORIES

PORTASPEZIE QUADRATO V
SQUARE SPICES CONTAINER V

Accessorio con barattoli in vetro dove riporre spezie, sali o alimenti di piccole dimensioni.

Accessory with glass jars where to store spices, salts or small food.

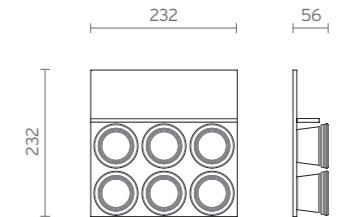

PORTASPEZIE QUADRATO N
SQUARE SPICES CONTAINER N

Accessorio con barattoli in vetro e tappo di chiusura a vite dove riporre spezie, sali o alimenti di piccole dimensioni.

Accessory with glass jars and screw cap where to store spices, salts or small food.

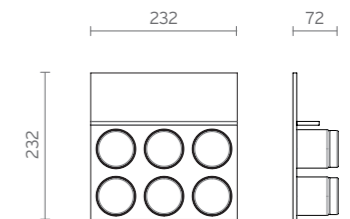

SET CONDIMENTI
SEASONING SET

Accessorio completo di 4 minimacine per spezie o sali e 2 innovative oliere da 250 ml in acciaio inox.

Accessory containing 4 small spices or salts grinders and 2 innovative 250 ml stainless steel cruets.

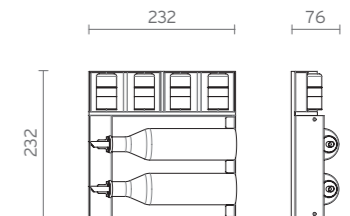

SET VINO
WINE SET

Elegante set dedicato agli amanti del vino. Contiene un cavatappi professionale Roero, tappo champagne, salva goccia, versatore vino in acciaio inox, preserva vino con due tappi in silicone.

Elegant set dedicated to wine lovers. It contains a Roero professional corkscrew, champagne cork, drop saver, stainless steel wine pourer, wine preserver with two silicone stoppers.

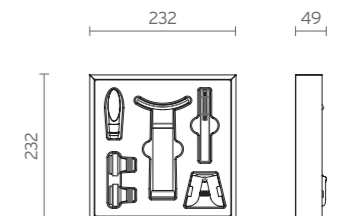

B ACCESSORI PORTAPOSATE FIT - FILO e CONTENITORI FRAME
FIT - FILO CUTLERY INSERTS and FRAME CONTAINERS ACCESSORIES

SET COCKTAIL
COCKTAIL SET

Accessorio elegante e pratico completo di strumenti per la preparazione di cocktails. Contiene shaker, jegger, pinza per ghiaccio e pestello.

Elegant and practical accessory complete with tools for cocktails preparation. It contains a shaker, jegger, ice pliers and pestle.

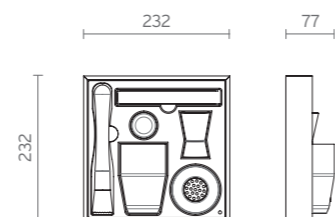

SET CROSTACEI
SEAFOOD SET

Set per l'apertura e il consumo di varie tipologie di frutti di mare, dai crostacei ai molluschi.

Set for opening and consuming different kinds of seafood, from shellfishes to clams.

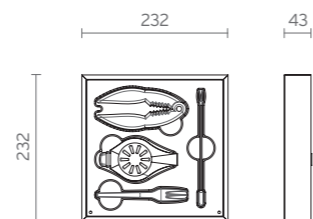

SET OSTRICHE
OYSTERS SET

Set per l'apertura di ostriche e bivalve. Contiene un guanto in maglia di acciaio inox e un coltello a lama piatta.

Set for opening oysters and bivalves. It contains a stainless steel chainmail glove and a flat-blade knife.

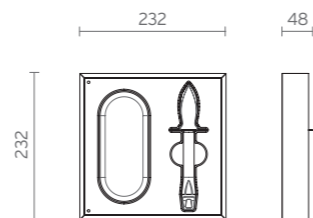

B ACCESSORI PORTAPOSATE FIT- FILO e CONTENITORI FRAME
FIT - FILO CUTLERY INSERTS and FRAME CONTAINERS ACCESSORIES

TAGLIERE DOUBLE FACE
DOUBLE FACE CUTTING BOARD

Comodo, pratico e funzionale tagliere in legno massello con finitura ad olio per uso alimentare. Non adatto al lavaggio in lavastoviglie.

Comfortable, practical and functional solid wood cutting board with oil finish for food use. Not suitable for washing in the dishwasher.

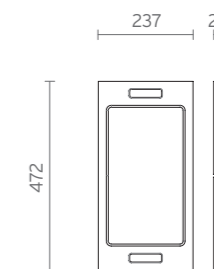

COMPENSATORE per profondità 60 cm PORTAPOSATE FIT - FILO
SPACER for depth 60 cm CUTLERY INSERTS FIT - FILO

Il compensatore viene utilizzato all'interno dei cassetti con profondità 60 cm. Può essere abbinato al fondo portaposate. Il compensatore è disponibile per cassetti da 45, 60, 75, 90, 105 e 120 cm di larghezza.

The spacer is used inside the 60cm deep drawers. It can be combined with the cutlery inserts base. The spacer is available for drawers of 45, 60, 75, 90, 105 and 120 cm width.

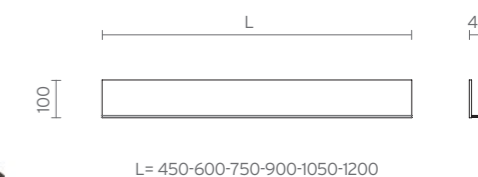

ACCESSORI DISPENSA FIT - FILO
PULL OUT ACCESSORIES FIT - FILO

PORTABOTTIGLIE
BOTTLES HOLDER

Contenitore con divisorio per riporre fino ad 8 bottiglie.

Box with dividers for storing up to 8 bottles.

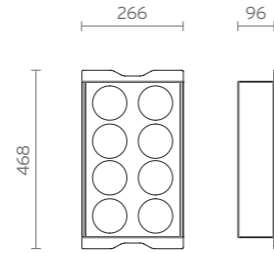

BOX ACCESSORI
ACCESSORIES BOX

Contenitore dove poter alloggiare bottiglie, vani per posate, contenitori o altri accessori.

Box for storing bottles, cutlery holders, containers and other accessories.

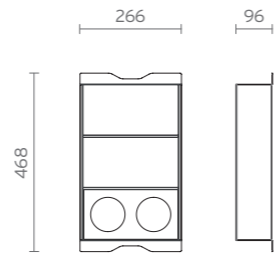

PORTABICCHIERI
GLASSES HOLDER

Vassoio con divisori per riporre fino ad 8 bicchieri.

Tray with dividers for storing up to 8 glasses.

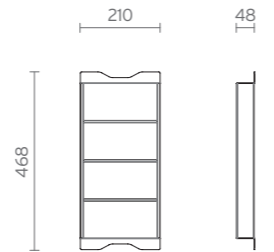

PORTAPIATTI
DISH HOLDER

Vassoio dove riporre ordinatamente fino a 11 piatti.

Tray to orderly store up to 11 plates.

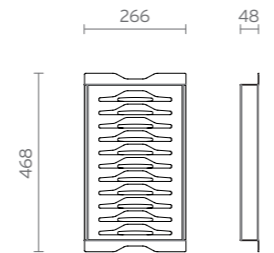

ACCESSORI DISPENSA FIT - FILO
PULL OUT ACCESSORIES FIT - FILO

SCOLAPIATTI
DISH RACKS

Vassoio scolapiatti dove riporre ordinatamente fino a 11 piatti.

Tray to orderly store up to 11 plates.

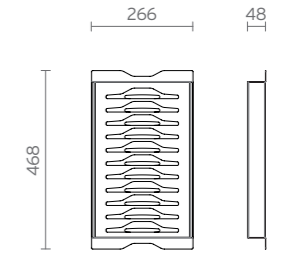

COMPENSATORE per profondità 60 cm DISPENSA FIT - FILO
SPACER for depth 60 cm PULL OUT FIT - FILO

Il compensatore viene utilizzato all'interno dei cassetti con profondità 60 cm. Può essere abbinato al fondo dispensa.

Il compensatore è disponibile per cassetti da 45, 60, 75, 90, 105 e 120 cm di larghezza.

The spacer is used inside the 60cm deep drawers. It can be combined with the pull out base.

The spacer is available for drawers of 45, 60, 75, 90, 105 and 120 cm width.

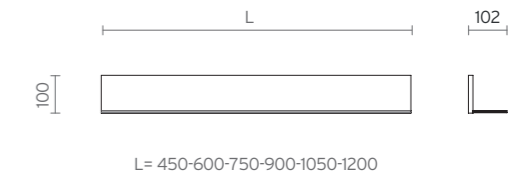





ESEMPIO DI CONFIGURAZIONE FILO PORTAPOSATE
FILO CUTLERY INSERT CONFIGURATION EXAMPLE

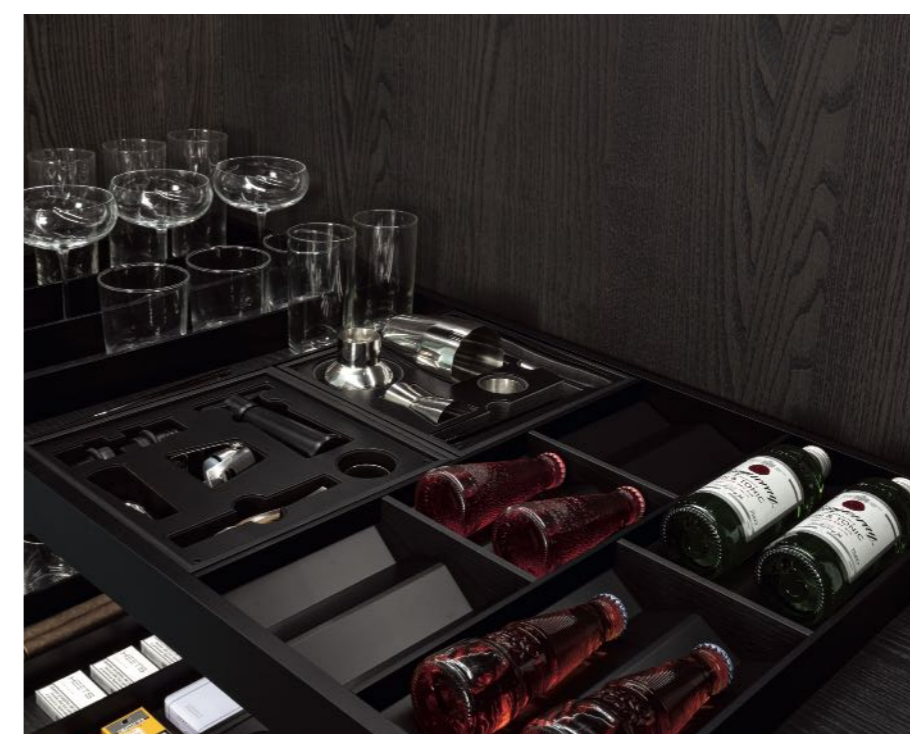

DETTAGLI SET CROSTACEI, SET OSTRICHE E RIPIANO COCKTAILS
SEAFOOD SET, OYSTERS SET AND COCKTAILS SHELF DETAILS

CONFIGURAZIONI E FINITURE ACCESSORI

Qualche suggerimento per ordinare e organizzare cassetti e dispensa, tenendo conto delle differenti misure e vani disponibili.

I 19 accessori pensati per i portaposate FIT, FILO e per alcuni contenitori FRAME, si inseriscono perfettamente all'interno dei divisori secondo gli schemi indicati di seguito.

Nelle versioni dispensa Fit e Filo lo spazio è invece più aperto e meno vincolante. Per questo motivo sono stati progettati delle eleganti, pratiche e funzionali box multiuso posizionabili in serie, parallelamente o perpendicolarmente all'apertura del cassetto.

Questi componenti esaltano e completano le funzionalità dell'intero sistema, permettendo di caratterizzare ciascuno spazio secondo le proprie necessità.

Tantissime combinazioni e una grande libertà nella scelta, con infinite possibilità da esplorare.

Some suggestions to tidy up and organize drawers and pull out, considering the different measures and spaces available.

The 19 accessories, thought for FIT, FILO and some of the FRAME shelves, perfectly fit into the dividers, as indicated in the following schemes.

In FIT and FILO pullout versions, the space is more open and less constraining. For this reason, some elegant, practical and functional multi-purpose boxes have been designed, to be positioned either in parallel or perpendicularly to the opening of the drawer.

These components exalt and complete the overall system functionality, allowing to define each space following each one's necessities.

Lots of combinations and a great freedom of choice, with countless possibilities to be explored.

ACCESSORI PORTAPOSATE FIT - FILO e CONTENITORI FRAME
 FIT - FILO CUTLERY INSERTS and FRAME CONTAINERS ACCESSORIES

A

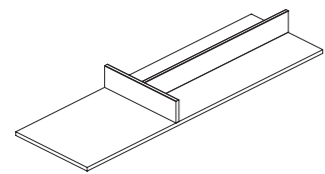

Divisorio a T
Partition T

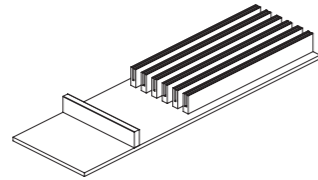

Portacoltelli
Knives Holder

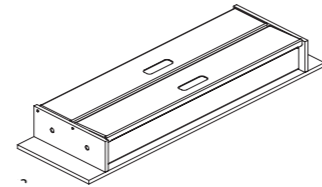

Portapellicole
Film Holder

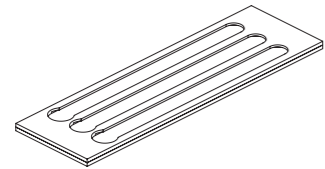

Portacialde
Pod Holder

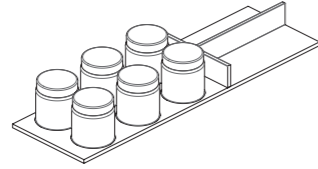

Portaspezie V
Spices Container V

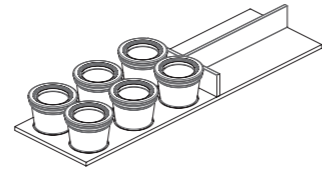

Portaspezie N
Spices Container N

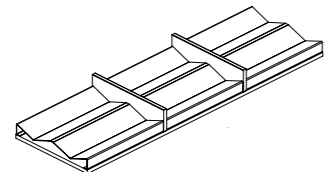

Portaspezie Universale
Universal Spices Container

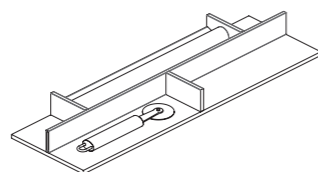

Set Pasta Fresca
Fresh Pasta Set

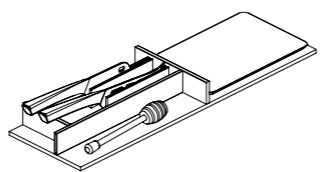

Set Formaggio
Cheese Set

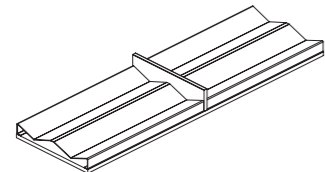

Portabibite
Drinks holder

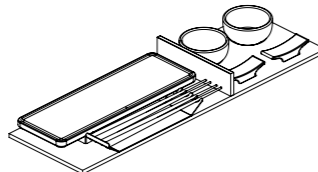

Set Sushi
Sushi Set

B

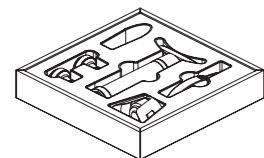

Set Vino
Wine Set

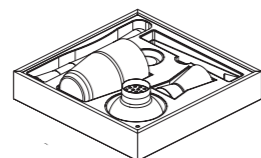

Set Cocktail
Cocktail Set

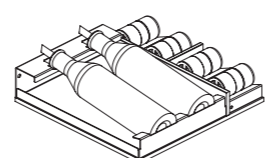

Set Condimenti
Seasoning Set



Portaspezie Quadrato V
Square Spices Container V

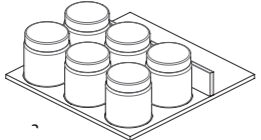

Portaspezie Quadrato N
Square Spices Container N

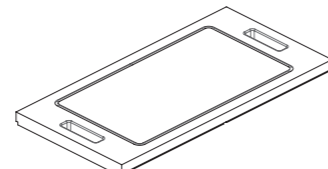

Tagliere
Cutting Board

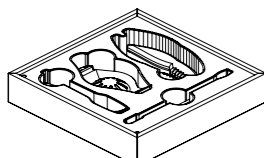

Set Crostacei
Seafood Set

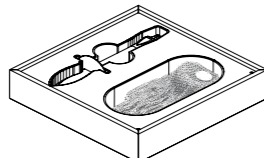

Set Ostriche
Oysters Set

CONFIGURAZIONI PORTAPOSATE FIT *
 CUTLERY INSERT CONFIGURATIONS FIT *

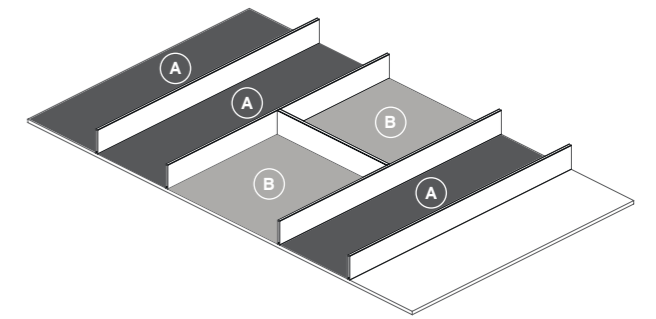
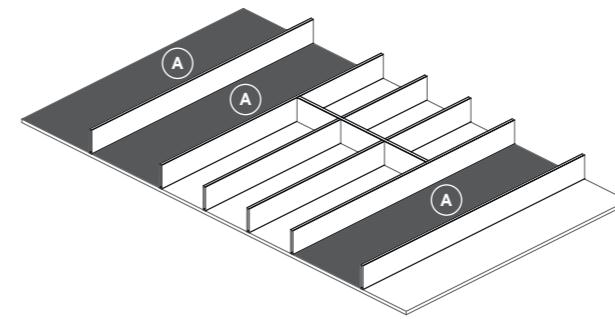

CONFIGURAZIONI PORTAPOSATE FILO *
 CUTLERY INSERT CONFIGURATIONS FILO *

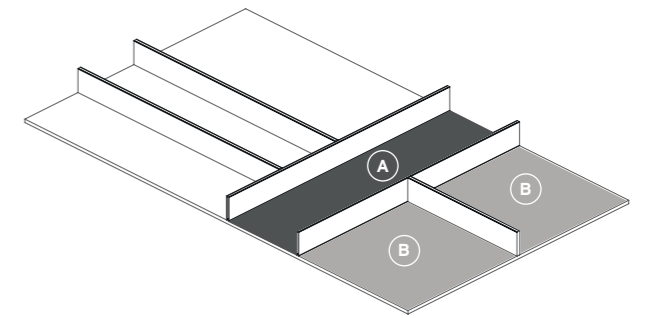
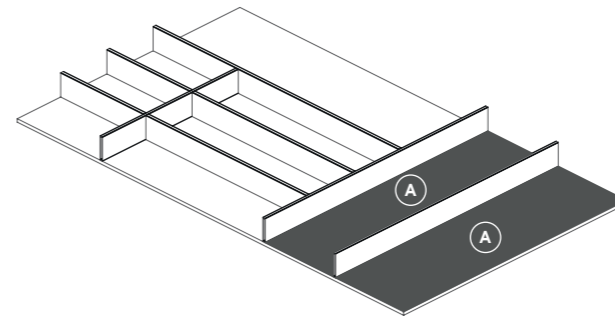

CONFIGURAZIONI CONTENITORI FRAME *
 FRAME SHELVES CONFIGURATIONS *

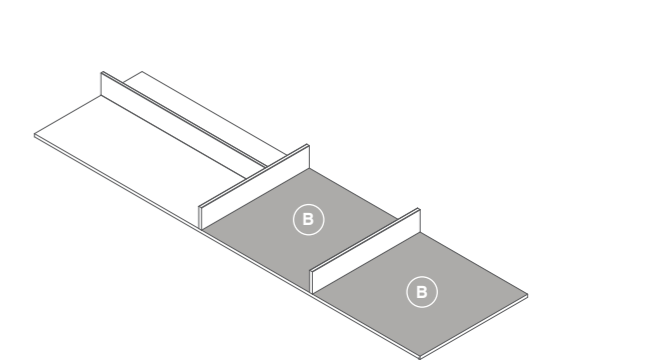
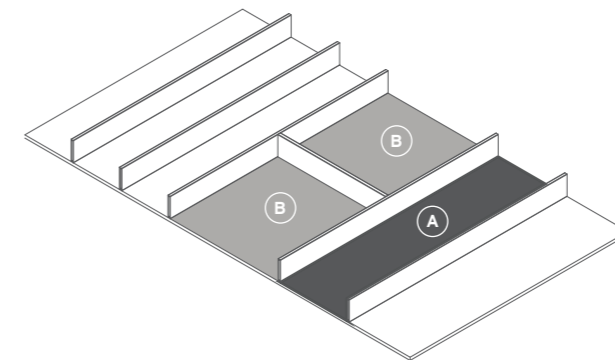

* Gli accessori possono essere inseriti solo negli spazi predisposti, come da schemi. * Accessories can only be inserted in the dedicated spaces, as by schemes.

FIT V1

FIT V2

FILO V1

FILO V2

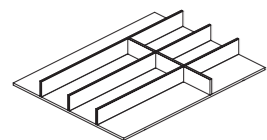

— 45 —

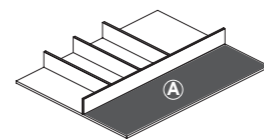
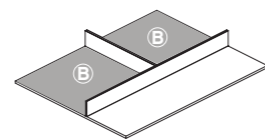

— 45 —

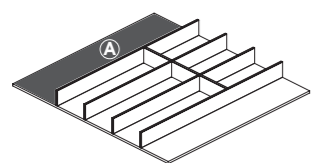
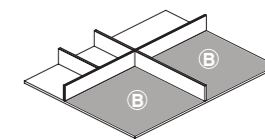

— 60 —

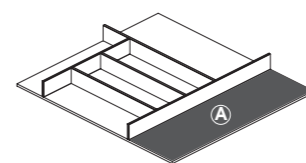
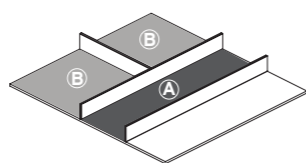

— 60 —

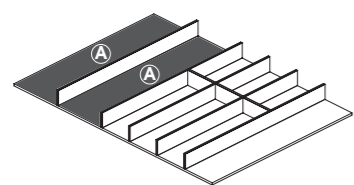
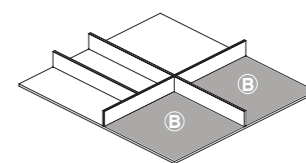

— 75 —

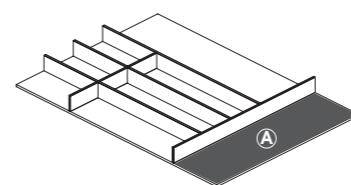
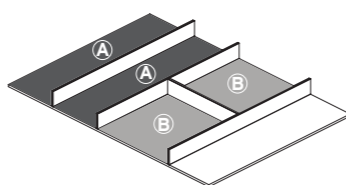

— 75 —

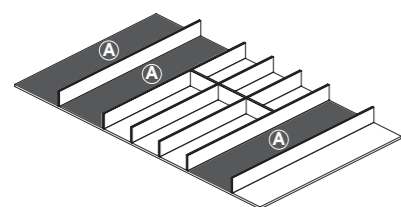
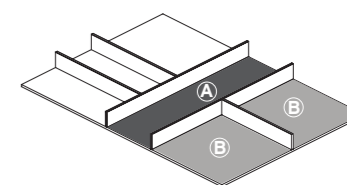

— 90 —

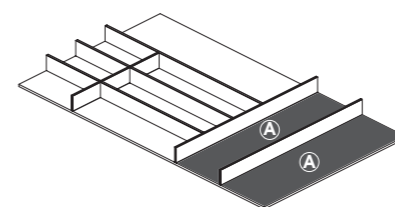
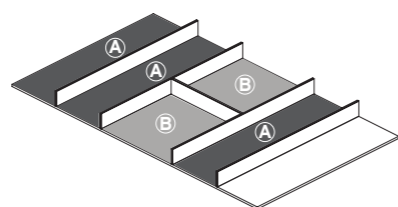

— 90 —

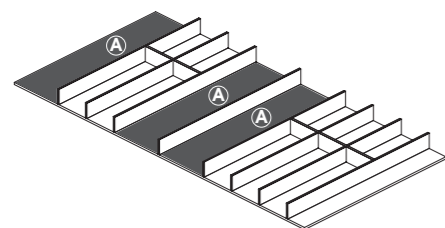
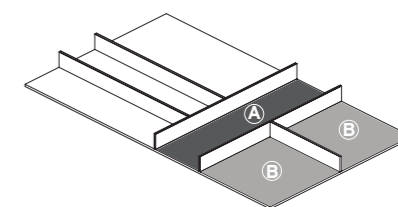

— 105 —

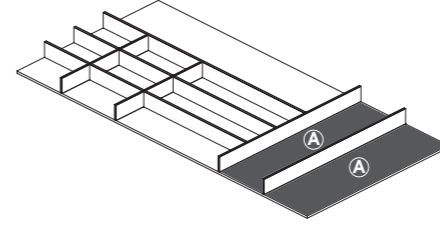
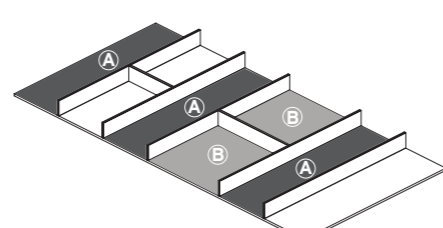

— 105 —

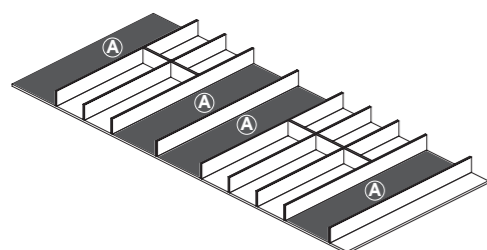
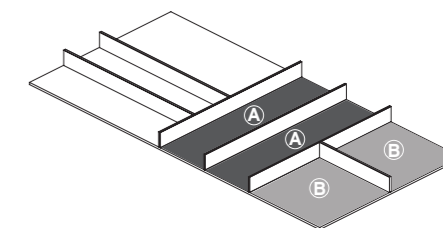

— 120 —

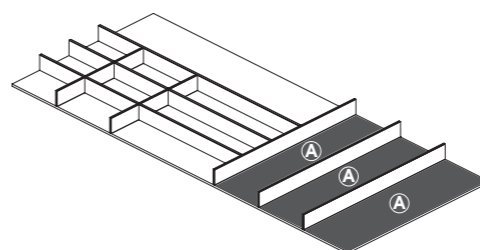
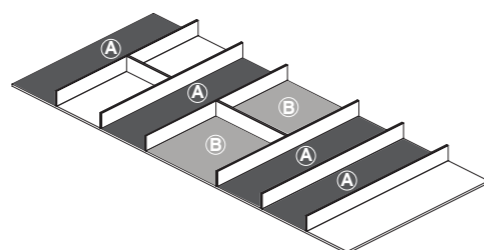

— 120 —

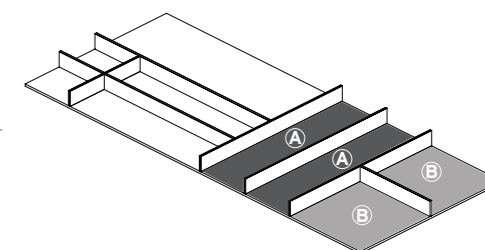

FRAME
PORTA ACCESSORI

FRAME
PORTABICCHIERI

FRAME
RIPIANO COCKTAILS

FRAME
PREPARAZIONE V1

FRAME
PREPARAZIONE V2

60

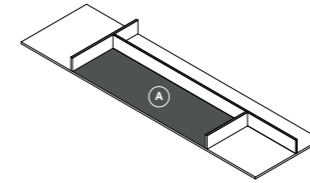
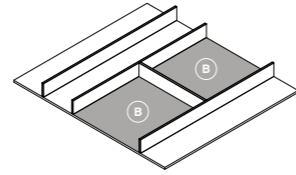
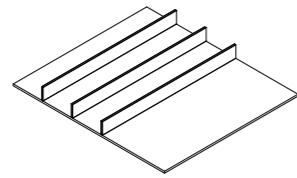
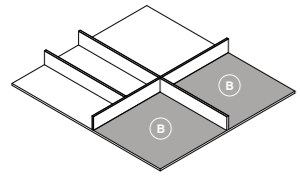

90

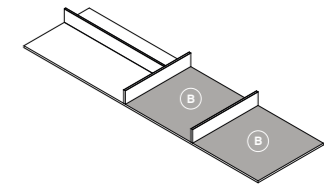

75

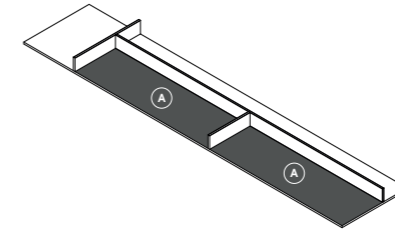
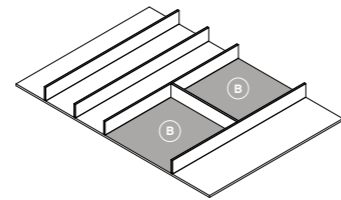
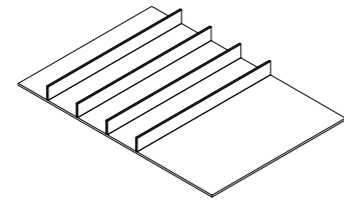
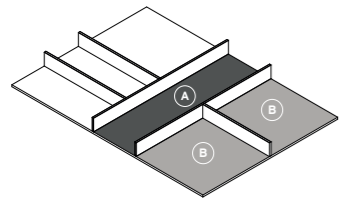

120

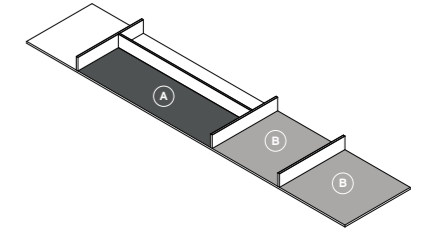

90

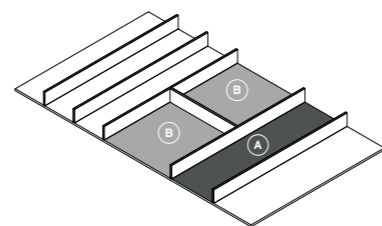
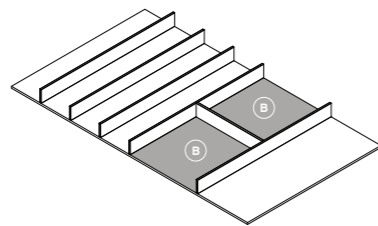
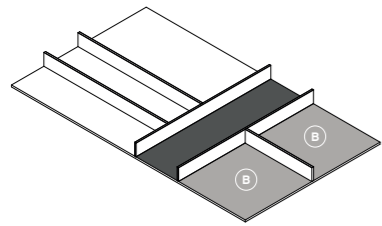

FRAME
PREPARAZIONE PLUS V1

FRAME
PREPARAZIONE PLUS V2

105

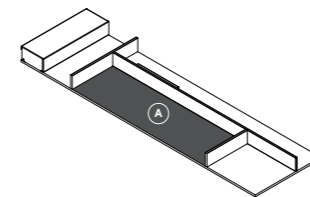
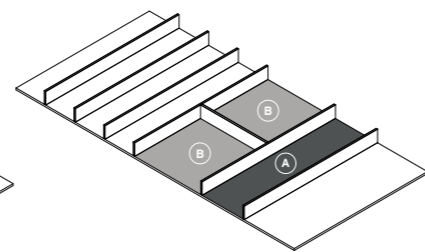
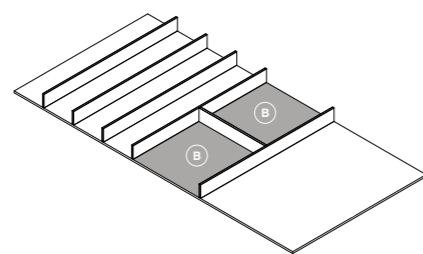
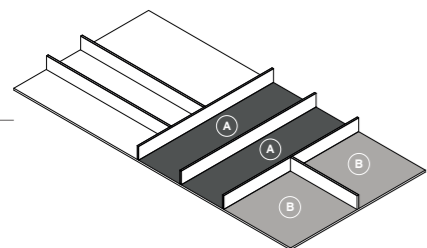

90

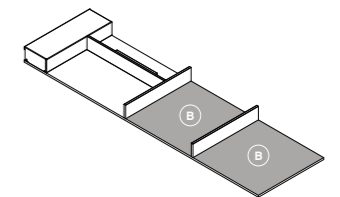

120

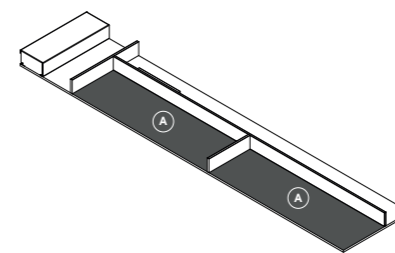
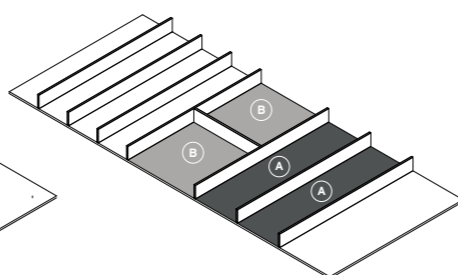
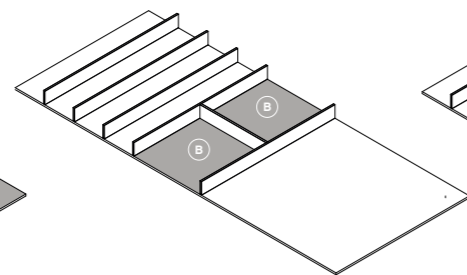
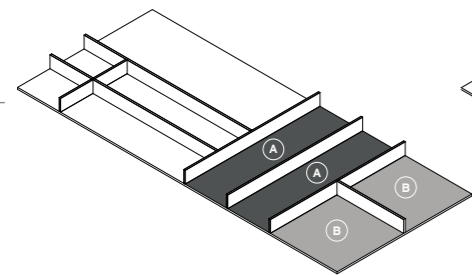

120

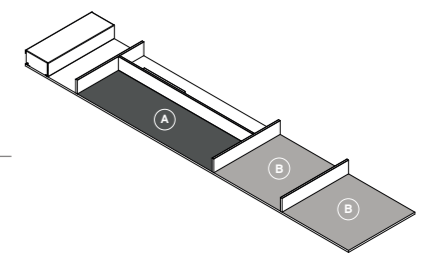

CONFIGURAZIONI DISPENSA FIT FILO V1 -V2
 PULL OUT CONFIGURATIONS FIT FILO V1 V2

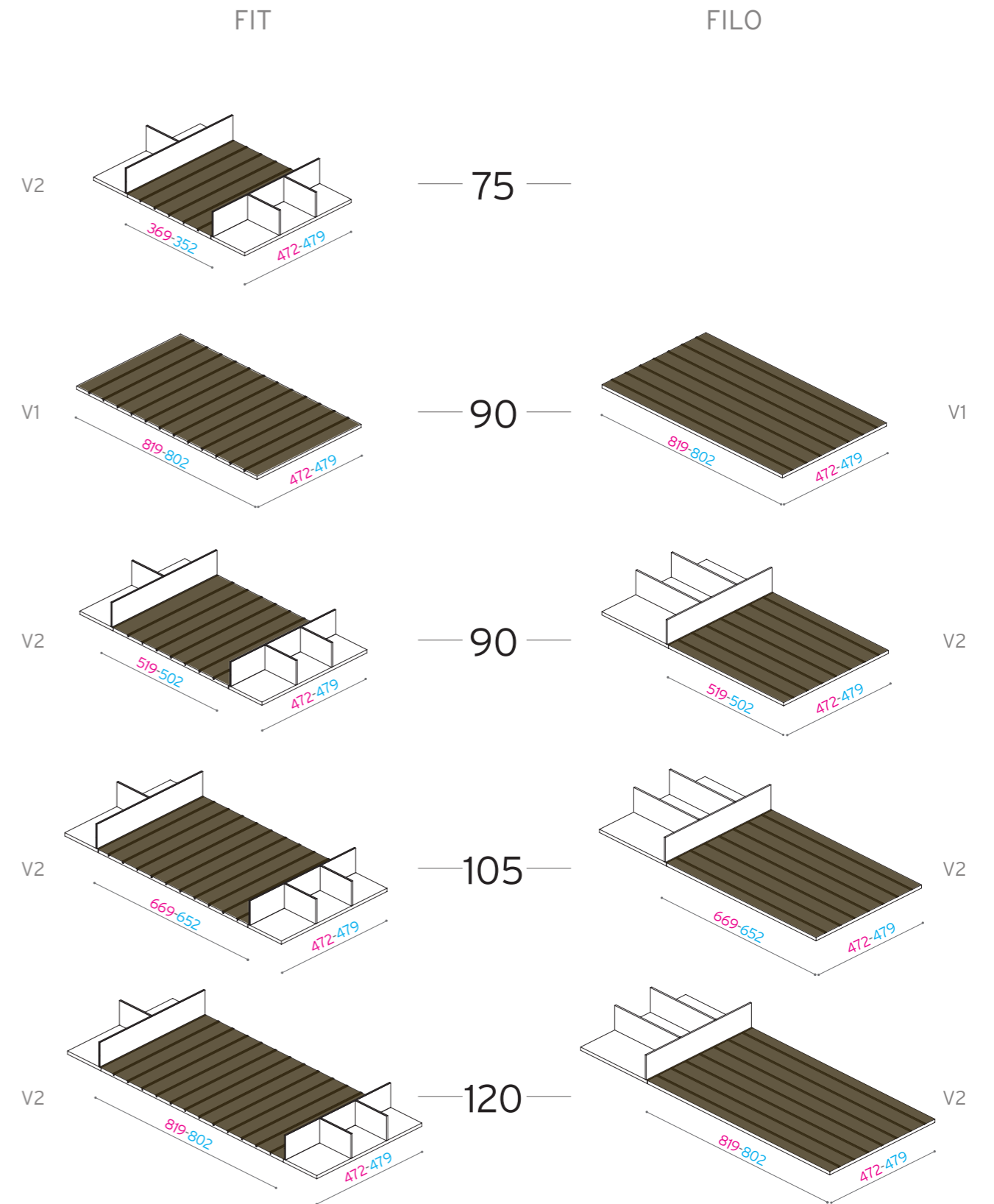
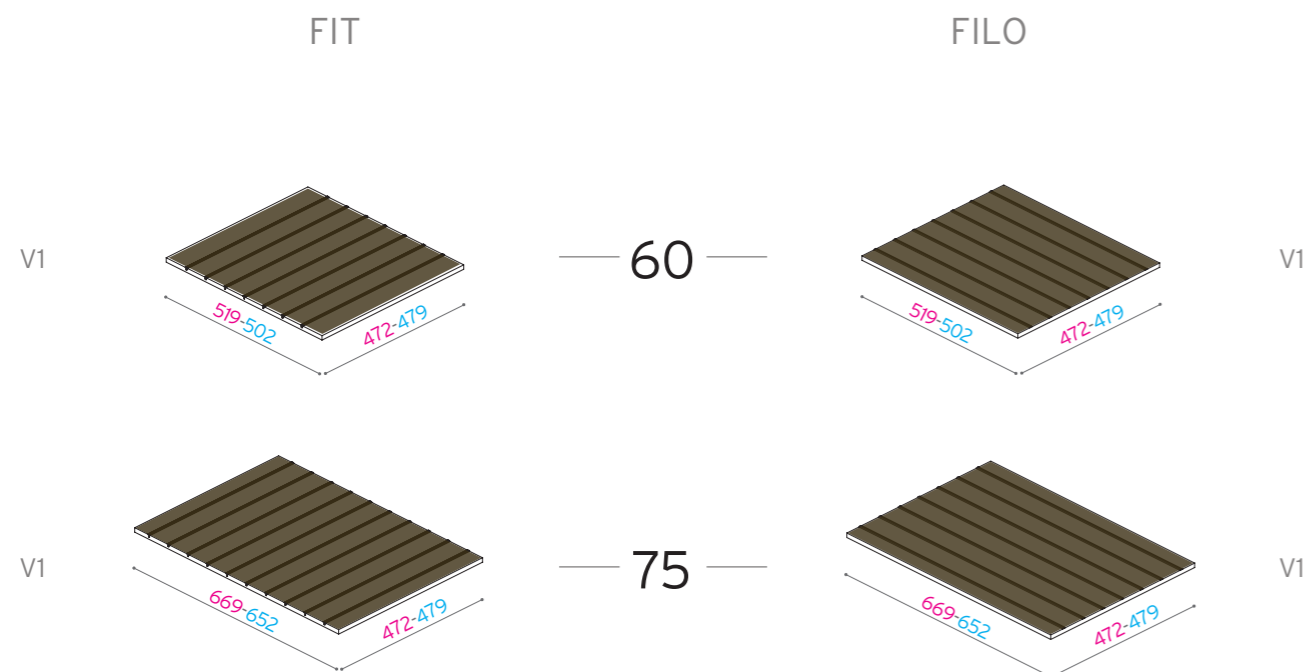
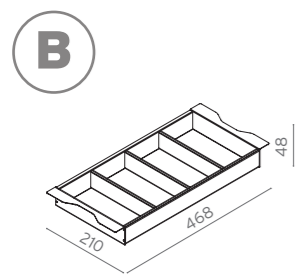
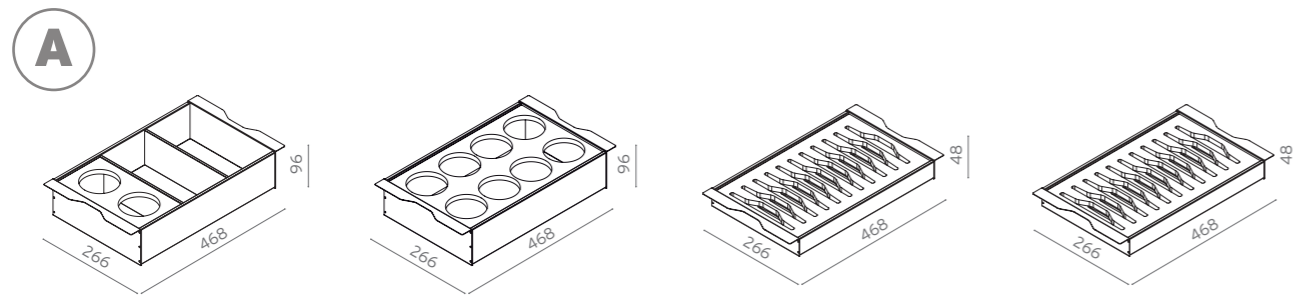

Gli accessori possono essere posizionati solo negli spazi colorati. Il limite di quantità è definito dalla larghezza del vano in relazione alla larghezza totale degli accessori scelti.

Accessories can be placed only in the colored spaces. The limit quantity is defined by the width of that spaces in relation to the total width of the chosen accessories.

FIT

FILO

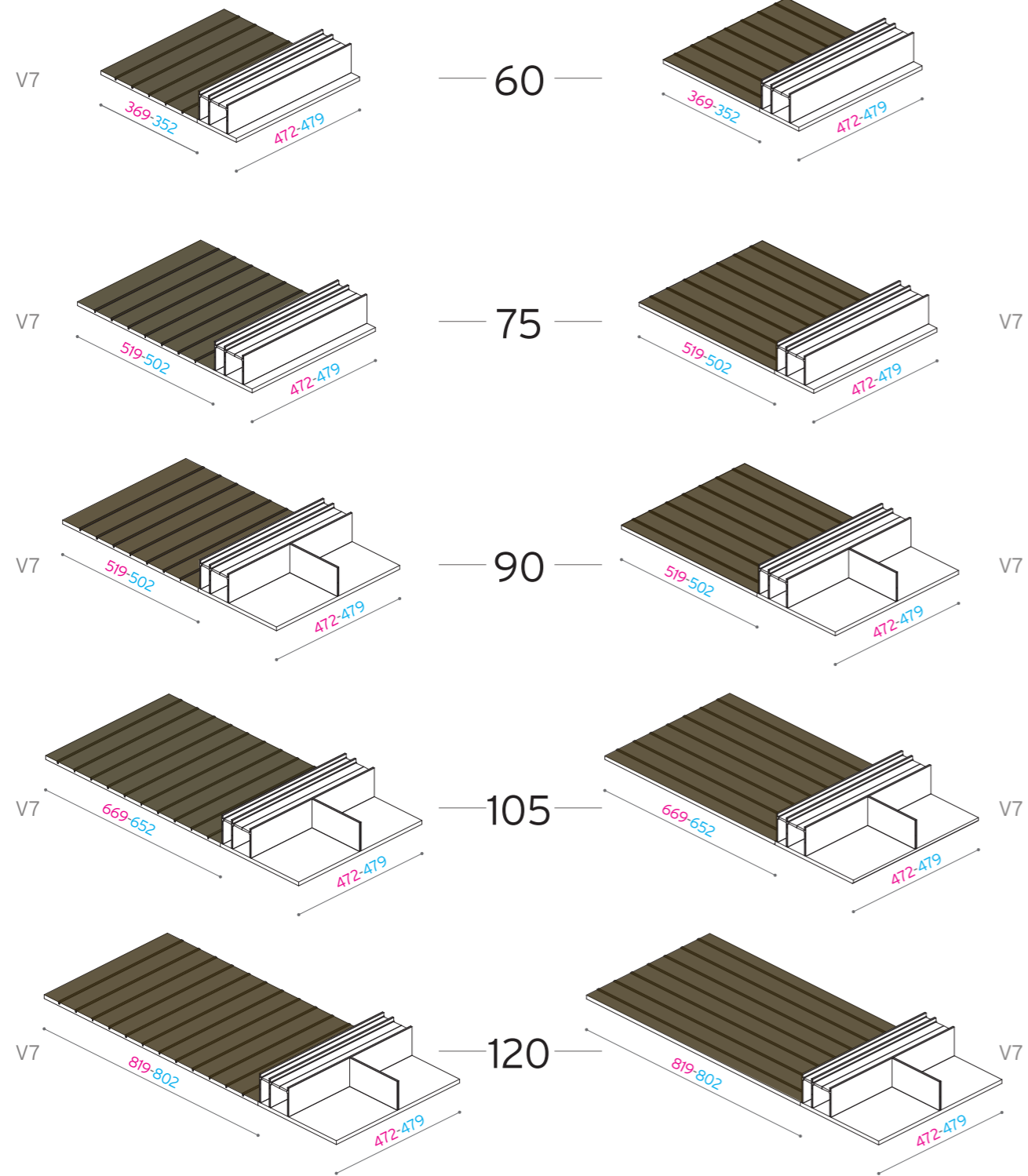

Gli accessori possono essere posizionati solo negli spazi colorati. Il limite di quantità è definito dalla larghezza del vano in relazione alla larghezza totale degli accessori scelti.

Accessories can be placed only in the colored spaces. The limit quantity is defined by the width of that spaces in relation to the total width of the chosen accessories.



FINITURE FINISHES

FONDO/DIVISORI ORIZZONTALI
BOTTOM/HORIZONTAL DIVIDERS

DIVISORI VERTICALI
VERTICAL DIVIDERS

FIT



Frassino tinto nero
Black stained ash

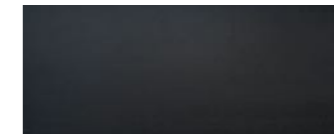

Alluminio anodizzato nero
Black anodized aluminium



Frassino tinto Moka
Moka stained ash

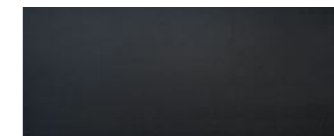

Alluminio anodizzato nero
Black anodized aluminium

FILO

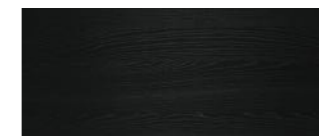

Frassino tinto nero
Black stained ash

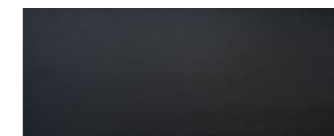

Alluminio anodizzato nero
Black anodized aluminium



Frassino tinto Moka
Moka stained ash

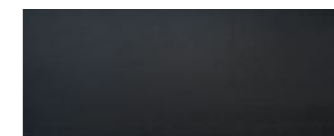

Alluminio anodizzato nero
Black anodized aluminium

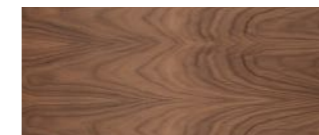

Noce Canaletto
Canaletto Walnut

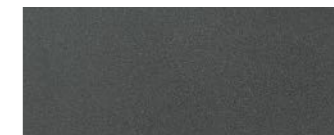

Alluminio verniciato titanio
Titanium painted aluminium

FRAME



Frassino tinto nero
Black stained ash

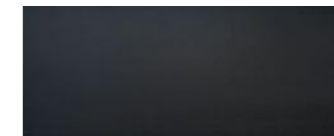

Alluminio anodizzato nero
Black anodized aluminium



Frassino tinto Moka
Moka stained ash

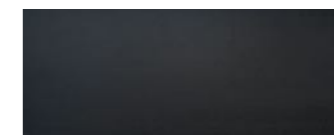

Alluminio anodizzato nero
Black anodized aluminium

L'elevata qualità dei prodotti Tecnoinox si manifesta anche nella scelta di materie prime che garantiscano un approccio responsabile nei confronti dell'ambiente.

Tecnoinox è pertanto un'azienda certificata **FSC®** e **CARB2**, garantendo l'origine e la tracciabilità dei materiali impiegati, unita al monitoraggio delle quantità di emissioni inquinanti prodotte durante la loro realizzazione.

La certificazione **FSC®** viene emessa dal **Forest Stewardship Council®**, un'organizzazione internazionale non governativa che promuove una gestione delle foreste del mondo ambientalmente adeguata, socialmente utile ed economicamente sostenibile. Per saperne di più, visita il sito fsc.org.

La certificazione **CARB2** viene emessa dalla California Air Resource Board, un'agenzia governativa americana nata con lo scopo di monitorare la qualità dell'aria e la salute dei cittadini. Questa certificazione garantisce dei valori massimi di formaldeide emessi nell'ambiente durante la produzione di pannelli in legno e compensato, utilizzati in molti dei prodotti Tecnoinox.

Infine, sempre in un'ottica di recupero e riciclo dei materiali, i prodotti Tecnoinox sono progettati massimizzando la semplicità nel disassemblaggio a fine vita, agevolando tutti i processi post-uso dei prodotti.

The high quality standards adopted in Tecnoinox products is also shown in the choice of environmental-responsible raw materials.

Tecnoinox is therefore an **FSC®** and **CARB2** certified company, ensuring the origin and traceability of the materials employed, together with the monitoring of pollutants emissions during their production.

The **FSC®** certification is emitted from the **Forest Stewardship Council®**, an international non-governmental organization, promoting a worldwide forests management being environmentally adequate, socially useful and economically sustainable, learn more on fsc.org.

The **CARB2** certification is emitted from the California Air Resource Board, an american government agency born to monitor air quality and citizen's health. This certification ensures for maximum values of formaldehyde emitted during the production of wooden and plywood panels, materials used in many Tecnoinox products.

Finally, to allow for materials reuse and recycling, Tecnoinox products are designed to maximise the ease of disassembly, facilitating all the post-use processes on industrial products.



Il marchio della gestione forestale responsabile

Richiedi i prodotti FSC®
Ask for FSC® certified products



L'azienda si riserva la facoltà di apportare, nel costante processo di miglioramento dei propri prodotti, qualsiasi modifica tecnica, dimensionale ed estetica che ritenga necessaria.

The company reserves the authority to perform, in the constant process of improving their products, any technical, dimensional and aesthetic modification which is considered necessary.

TECNOINOX

Tecnoinox s.r.l.
20825 Barlassina (MB), Italia
Via Longoni 112/114
Tel. +39.0362.563327
Fax +39.0362.557966

www.tecnoinox.it
contact@tecnoinoxsrl.it
info@tecnoinoxsrl.it

FOTO
Azimak
PROGETTO GRAFICO
Silvia Gerli
FOTOLITO
gm Studio1
STAMPA
Grafica Gioia
07.2023

